

Q-Pumps

THE BEST SOLUTION FOR YOUR
SANITARY PROCESSES

ZP3 Series

Installation and Maintenance Manual



Table of Contents

Introduction	3
Introduction	3
General Information	3
Shipping Damage or Loss	3
Pump Receiving	3
Safety	4
Safety	4
Pump Information.....	5
Pump Information	5
Label Information.....	6
Installation	7
Installation	7
Base Arrangement	7
Piping and Connections.....	8
Check/ Isolation/ Relief Valves.....	9
Strainers and Gauges.....	10
Base Alignment	10
Pump Rotation.....	11
Seal Flush	11
Maintenance.....	12
Maintenance	12
Pump Lubrication.....	12
Preventive Maintenance/ Inspection	13
Gear and Bearing Inspection	14
Annual Maintenance	15
Cleaning	15
Pump Disassembly	16
Single Seal Maintenance	17
Double Seal Maintenance	20
Disassembly	20
Assembly	20
Seal Cutaways	21
Pump Clearances	22
Pump Assembly	23
Exploded View.....	24
Gear Case Maintenance.....	25
Disassembly	25
Assembly	27
Q-Pumps Available Options	32
Troubleshooting.....	33
Remanufacturing Program	36
ATEX Certification Information	37
Q-Pumps Terms and Conditions.....	38
Return Policy	41

Introduction

Introduction

To ensure the best results and service, please read and fully understand this manual prior to putting this pump into service. For any questions regarding operation, maintenance, or installation, please contact your Distributor or Q-Pumps. Q-Pumps contact information is as followed:

Q-Pumps S.A. de C.V.
Acceso "A" #103, Fracc. Ind. Jurica
Querétaro, Qro. México, 76130
Phone: +52 (442) 218 4570 or +52 (442) 103 3100
Fax: +52 (442) 218 4577
Email: sales@qpumps.com

General Information

Each ZP3 pump is fully assembled, lubricated, and tested at the factory and shipped ready for use. Standard maintenance practices are outlined in this manual. For more information, please refer to the Maintenance section. Following these guidelines will provide long-lasting, trouble-free service when the pump(s) is incorporated in a properly designed system.

Shipping Damage or Loss

Upon receiving equipment that is damaged or if your shipment is lost in transit, immediately file a claim with the carrier. At time of pick-up, the carrier signed the bill of lading, acknowledging that they have received the product from Q-Pumps in good condition.

Receiving/Safety

Pump Receiving

Q-Pumps covers the pump inlet and discharge ports prior to shipping, ensuring that foreign matter does not enter the pump during shipment. If the protective covers are missing upon arrival, remove the pump cover and inspect to ensure it is free from contaminate before turning the shafts. Please make note of the pump serial number; this will assist in the process of ordering replacement parts and/or a warranty claim. For more information regarding shipment damage or warranty, please refer to Terms and Conditions.

Safety

IMPORTANT: Read and understand this manual BEFORE installation, operation or maintenance of the pump. Improper installation, operation, or maintenance may result in severe injury or death. Equipment damage caused by user neglect will invalidate the pump warranty.

There are safety symbols used throughout this manual identifying safety concerns.



WARNING: Hazards or unsafe practices that COULD result in severe personal injury or death, and how to avoid them.

CAUTION: Hazards or unsafe practices that COULD result in minor personal injury or damage to product or property.

Pump Information

Pump Information

The design of the ZP3 pump gear case allows for the shaft location to be universal in order to fit any system requirement. This can be seen in Figures 1 and 2:

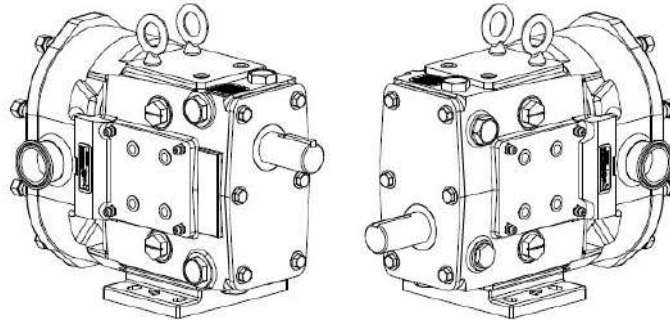

Figure 1: Shaft Mounts (Upper and Lower)

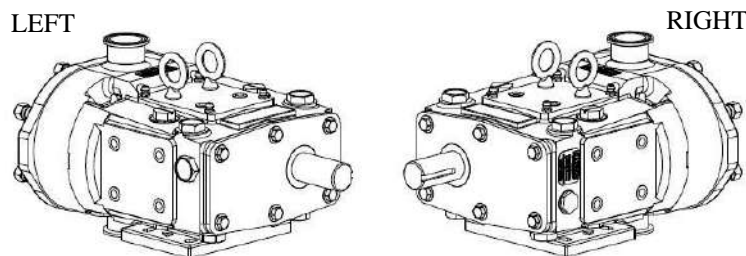

Figure 2: Shaft Mounts (Left and Right)

Table 1: Standard Operating Parameters

Model	Maximum Nominal Capacity		Displacement		Maximum Differential Pressure		Temperature Range		Standard Connection Size		Optional Connection Size		Maximum Speed	
	GPM	M ³ /hr	Gal. / 100 rev	Liters / rev	PSI	Bar	° F	° C	in.	mm	in.	mm	Rev/min	
ZP3 6	8	1.8	0.8	0.030	300	21	-40° to 200°	-40° to 93°	1.5"	38	1"	25	1000	
ZP3 15	11	2.5	1.4	0.052	250	17			1.5"	38	-	-	-	800
ZP3 18	20	4.5	3.0	0.108	200	14			1.5"	38	2"	51	51	700
ZP3 30	36	8.2	6.0	0.227	250	17			1.5"	38	2"	51	51	600
ZP3 40	46	10.4	7.6	0.288	150	10.3			2"	51	2.5"	64	64	600
ZP3 45	58	13.2	10.0	0.366	450	31			2"	51	-	-	-	600
ZP3 60	90	20.4	15.0	0.568	300	21			2.5"	64	3"	76	76	600
ZP3 130	150	34.1	25.0	0.946	200	14			3"	76	4"	102	102	600
ZP3 180	230	52.2	38.0	1.450	450	31			3"	76	-	-	-	600
ZP3 210	300	68.1	50.0	1.900	500	34			4"	102	-	-	-	600
ZP3 220	310	70.4	52.0	1.980	300	21			4"	102	-	-	-	600
ZP3 320	450	102	75.2	2.847	300	21			6"	152	-	-	-	600

Pump Information

Table 2: Rectangular Flange Model Operating Parameters

Model	Maximum Nominal Capacity		Displacement		Maximum Differential Pressure		Temperature Range		Rectangular Inlet (W x L)		Outlet		Maximum Speed
	GPM	M ³ /hr	Gal. / 100 rev	Liters / rev	PSI	Bar	° F	° C	inches	in.	mm	Rev/ min	
ZP3 34	24	5.4	6.0	0.22	250	17	-40° to 200°	-40° to 93°	1.75 x 6.75	2"	50	400	
ZP3 64	60	13.6	15.0	0.57	300	21			2.24 x 8.82	2½"	65	400	
ZP3 134	100	22.7	25.0	0.96	200	14			2.97 x 9.25	3"	76	400	
ZP3 184	152	34.5	38.2	1.43	450	31			3.28 x 11.25	3"	76	400	
ZP3 214	200	45.4	50.2	1.90	500	34			3.45 x 12.70	4"	102	400	
ZP3 224	208	47.2	52.1	1.97	300	21			3.87 x 11.00	4"	102	400	
ZP3 324	401	91	75.2	2.75	300	21			4.25 x 12.70	6"	152	400	

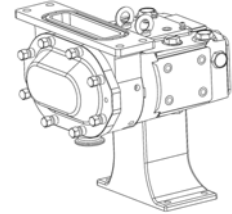

- For operating parameters that fall outside the standard values defined in Table 1 and Table 2, please contact the Engineering Department at Q-Pumps (+52 (442) 1033 100).
- Standard rotors operate within a temperature range of -40°F to 200°F . Hot clearance rotors operate between 180°F to 300°F . Consult Q-Pumps for questions on application factors such as temperature, operational speed, and differential pressure.

Label Information



WARNING: Labels are installed on the pump at the factory to ensure proper warning to users. Do not remove these labels; doing so may result in injury. The pump is installed with simple, but effective labels to help the customer better understand the ZP3 pump. An identification plate is applied at the factory to help track the life of the pump. The customer should be aware of the pump's serial number and model number prior to contacting Q-Pumps with any concerns. These labels can be seen below in Figure 3:

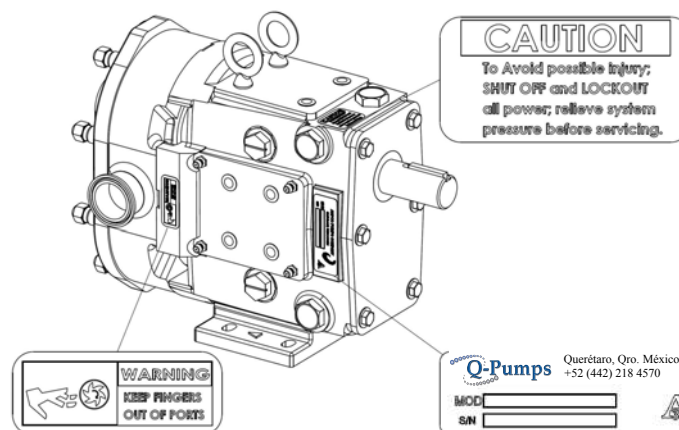

Figure 3: Important Label Information

Installation

Installation

Follow local codes and restrictions when installing the pump and piping system. The practices outlined in this manual are intended to ensure the most optimal performance of the pump.

Base Arrangement

The standard installation arrangement for a pump of this type consists of both the pump and drive unit mounted on the same base plate. Typical base plate arrangements consist of permanently fixed bases, bases with leveling and/or vibration isolation pads, bases with attached adjustable legs, or portable/wheeled bases. All base arrangements must be level during operation. Standard base configurations (base, pump, coupling, coupling guard, gear reducer, and motor) can be seen below in Figure 4.

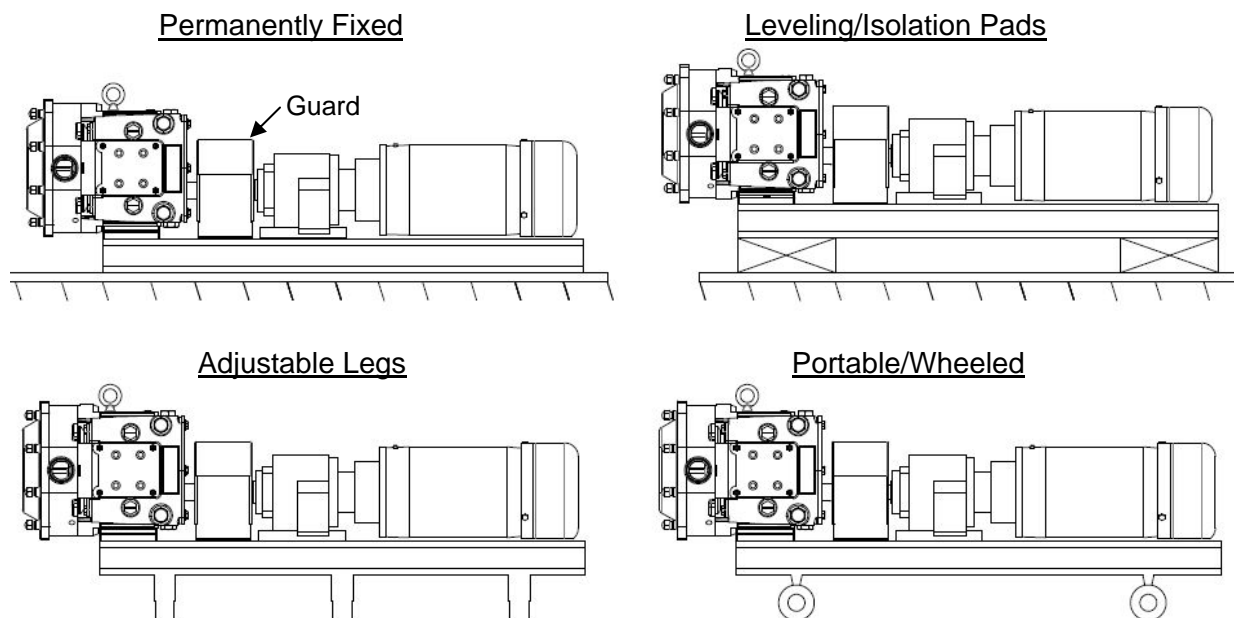

Figure 4: Base Layout Examples



WARNING: To ensure safety, protective guards must be properly installed over all external rotating parts and components. Failure to do so may result in injury. Q-Pumps provides protective guards for complete base packages (pump and drive unit).

Installation

Piping and Connections

It is important to minimize forces imposed on the pump. This can be done by independently supporting the piping going to and from the pump. Excessive force applied to the pump can cause misalignment of internal parts which leads to the premature wear of rotors, bearings, and shafts. The use of hangers and pedestals on connecting pipes will help avoid such misalignment. Examples of such supports can be seen in Figure 5.

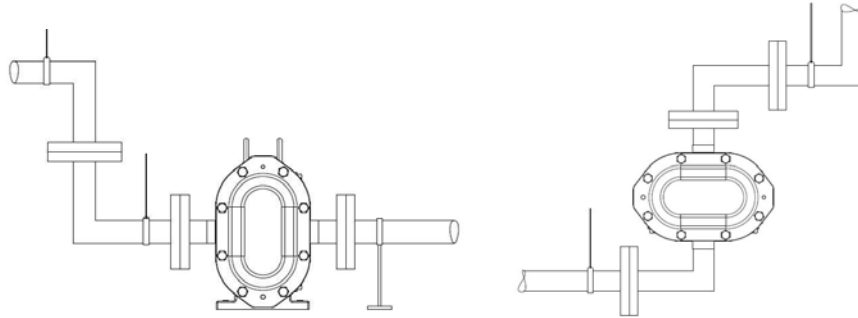

Figure 5: Piping Support Example

It is not recommended to weld custom fittings outside the factory. Shrinkage and warpage can occur to the pump housing which will affect the life and performance of the pump.

To prevent air pockets from entering the pump from the inlet, install the pump below the supply (Figure 6). This will create a constant supply of product on the suction side, and reduce the chance for air to enter the pump. Sloping the piping on the inlet side away from the pump will prevent air pockets if the pump is installed above the supply (Figure 7).

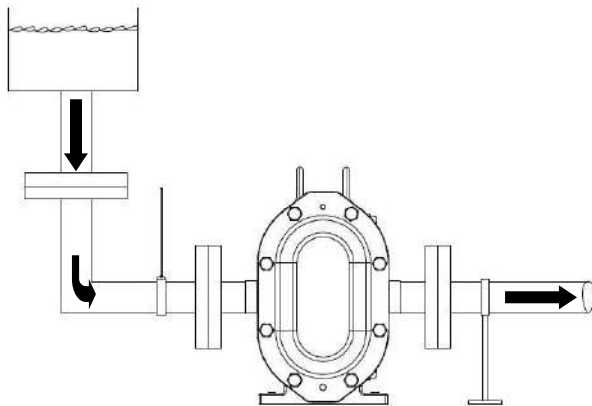

Figure 6: Correct Piping (Supply Above)

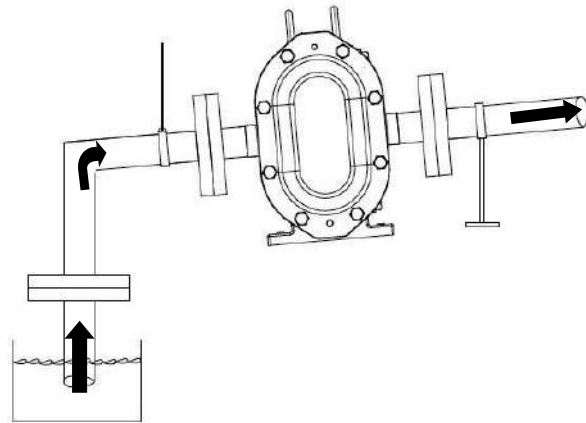

Figure 7: Correct Piping (Supply Below)

Installation

Check/ Isolation/ Relief Valves

Check valves should be used on the inlet side for any application when the product is lifted (Figure 8). This is to ensure a full inlet and is especially important with low-viscosity fluids. If the system has liquid under a vacuum, such as closed tank applications, it is important to have a check valve on the discharge side to prevent backflow during initial start-up (Figure 9).

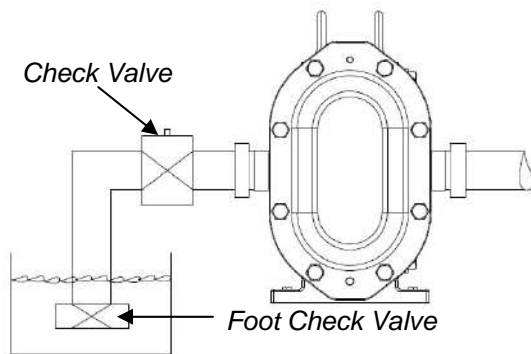

Figure 8: Check Valve (Inlet Side)

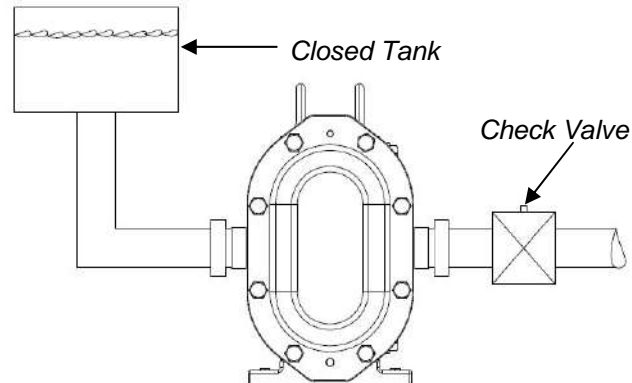

Figure 9: Check Valve (Discharge Side)

When shut down time is not possible, a bypass system may be installed with a backup pump in parallel to allow production to continue while maintenance is performed on the down pump. Isolation valves may also be used on both the inlet and discharge sides of the pump to shut down the flow of product to the pump. This will allow for maintenance and removal of the pump without draining the entire system and risking the loss of product.



CAUTION: Q-Pumps ZP positive displacement pumps are designed with extremely tight tolerances allowing only low slip internally between rotors and pump housing. DAMAGE will occur if the pump is operated with discharge or inlet lines closed. **DO NOT** operate pump with lines closed.

In order to prevent damage to the pump, it is recommended a relief valve be installed on the pump's discharge side. The relief valve can either divert flow into a drain or back to the inlet side (Figure 10).

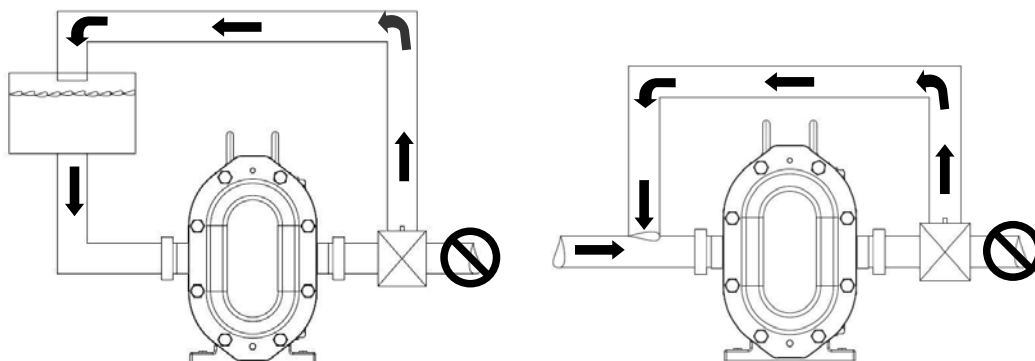

Figure 10: Relief Valve Examples

Installation

Strainers and Gauges

Strainers and magnetic traps should be used to prevent foreign matter from entering the pump. It is essential to service strainers and traps regularly to prevent restriction of flow. To determine the performance of the pump, install pressure and vacuum gauges on the inlet and discharge piping (Figure 11).

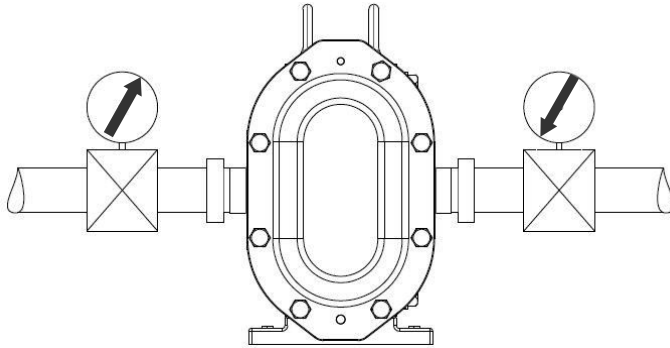

Figure 11: Proper Gauging

Proper Gauging Shows:

- Unusual pressure variations
- Indicates flow
- Changes in pump performance
- Variations in the system
- Differences in fluid viscosities

Base Alignment

Pump and base assemblies sent directly from Q-Pumps factory are aligned prior to shipment. Assemblies must be checked once they are installed and prior to operation. Misalignment may cause unnecessary wear and shorten the life of the pump. If couplings are not specified, Q-Pumps will use a flexible coupling which permits minor compensation for alignment and endplay.

To check the coupling alignment, start with checking the angular alignment by measuring the gaps between the couplings on both the pump and motor side (Figure 12, Angular Alignment). Shim the assembly accordingly so the gap is equal distance at all points. Next, using a straight edge, check the horizontal and vertical alignment of the coupling. Place the straight edge along the coupling to ensure that both sides are concentric (Figure 12, Parallel Alignment).

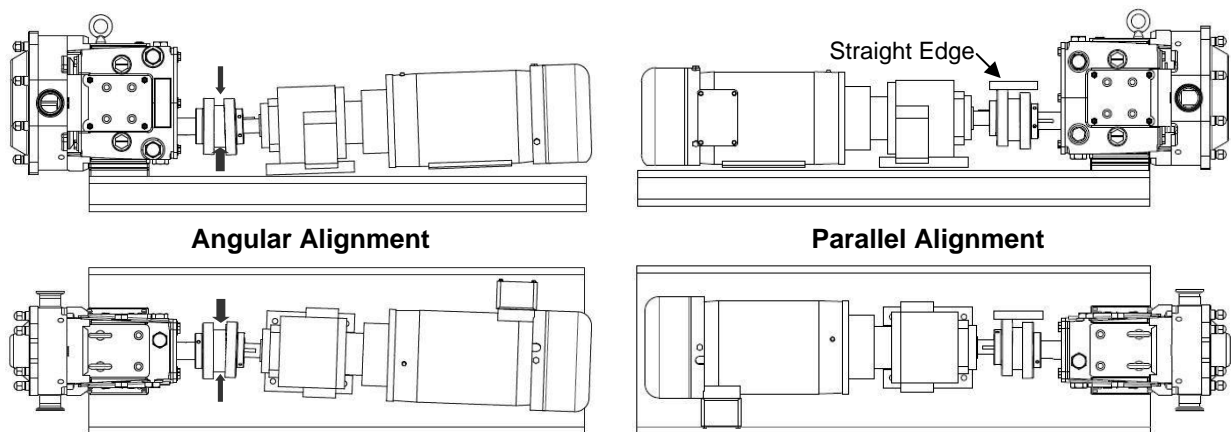

Figure 12: Check Alignment

Installation

Pump Rotation

Check the direction of rotation (both on drive unit and pump) prior to connecting the pump to the drive. This will ensure correct product flow at start-up (Figure 13 and Figure 14). Also check that the pump turns freely and is free of any foreign contaminants. Connect the pump and check to make certain all guards are in place.

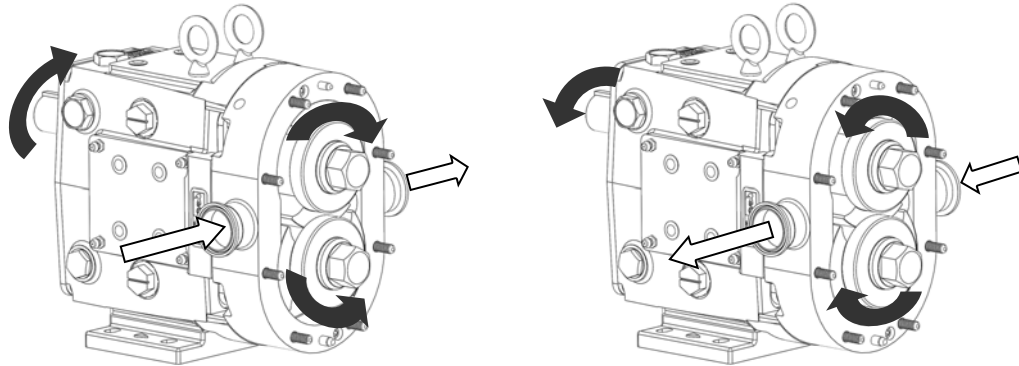

Figure 13: Top Drive Shaft

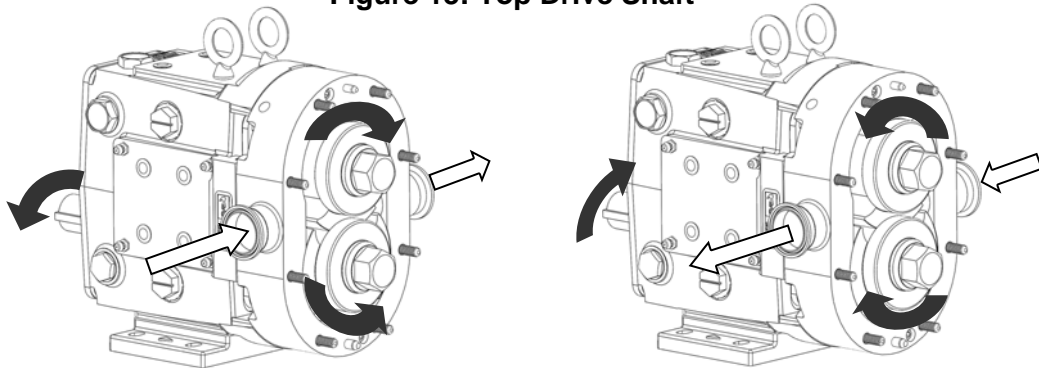

Figure 14: Bottom Drive Shaft

Seal Flush

For pumps with double seals, connect seal flushing before operation. Operation of the pump without proper flushing will **damage** seal faces. Flushing connections are typically 1/8" female NPT with one side being the inlet and the other the discharge. Flush from the bottom to the top, using the lower connection as the inlet and the upper connection as the discharge. This ensures that air is removed from the flush line with the flush area completely flooded (Figure 15). Flush flow rate should be 1/4 GPM (30 psi max pressure). For high temperature applications flush flow may be increased to remove excess heat.

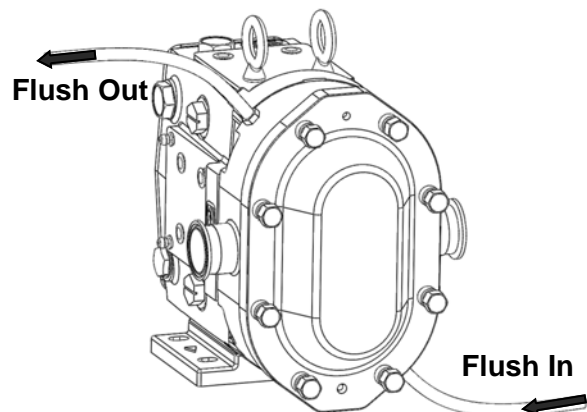

Figure 15: Proper Flushing for ZP3 Double Seal

Maintenance

Maintenance



WARNING: Before attempting service on the pump or motor, DISCONNECT the energy source to the pump. This will help prevent accidental start-up and serious injury.

The Q-Pumps ZP3 pump is designed to be easily disassembled for cleaning and maintenance purposes. When performing maintenance on the pump it is important to inspect all wetted parts for standard wear and damage. For inspection instructions please see page 13. For rebuild information, see PD Pump Remanufacturing Program details on page 36. Prior to disconnecting the pump, shut off all inlet and discharge valves, drain the pump (rinse if necessary), and turn off all electrical supply to the pump (follow standard lock out procedures).

Pump Lubrication

Proper lubrication of gears and bearings is vital to the life of the pump. For pumps assembled on bases with a gear reducer and motor, please refer to the proper manufacturer manual for lubrication requirements. These manuals are sent with the pump from the factory. Important lubrication points can be seen in Figure 16.

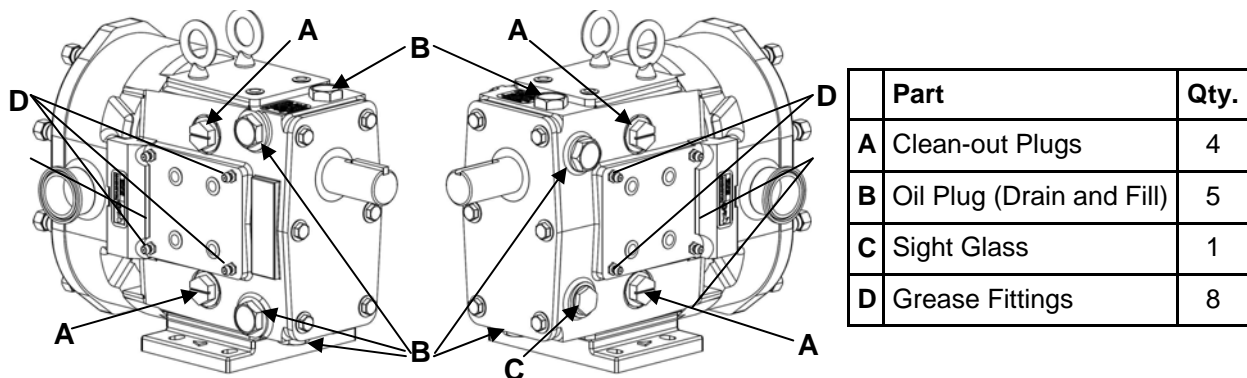

Figure 16: Lubrication Points

Both gears and bearings are shipped factory-lubricated with grease and oil. The oil used to lubricate the gears should be changed every 500 hours with the quantities shown in Table 3. The bearings should be re-greased every 250 hours. Excessive grease may build up inside the gear case and should be cleaned out through the clean-out plugs shown in Figure 16, A.

Table 3: Oil Capacity (Gears)			Table 3: Grease Quantity (Per Bearing)	
ZP3 Model	Top/Bottom Shaft	Side Mount	Front	Rear
6, 15, 18	1.3 oz (40ml)	3.3 oz (100ml)	.37 oz (11cc)	.13 oz (4cc)
30, 34, 40	2.0 oz (60ml)	4.0 oz (120ml)	.60 oz (18cc)	.21 oz (6cc)
45, 60, 64 130, 134	6.0 oz (170ml)	9.5 oz (280ml)	.84 oz (25cc)	.76 oz (22cc)
180, 184, 220, 224	11 oz (320ml)	20 oz (600ml)	1.33 oz (39cc)	1.03 oz (30cc)
210, 214, 320, 324	17 oz (500ml)	44 oz (1300ml)	1.96 oz (58cc)	1.16 oz (34cc)

Oil Specifications: ISO Grade 320, SAE 140 or AGMA Number 6EP

Grease Specifications: Halo-Guard FG-2, NSF H1 FOOD-GRADE, NLGI Grade No. 2

Maintenance

Preventive Maintenance/Inspection

While performing standard maintenance or cleaning, check for signs of damage or extreme wear. A simple inspection may show signs of a problem long before it becomes serious. Detection of such problems can avoid costly repairs and reduce down time. Remove the cover and inspect the rotor tips to ensure that there is no metal-to-metal contact between the rotors. Measure the clearance between the rotor tips as seen in Figure 17. The clearance should be equal on both sides. If contact is detected, rotors may require replacement.

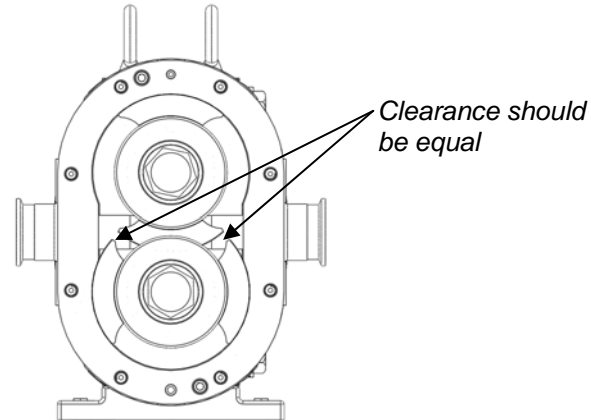

Figure 17: Clearance Between Rotor Tips

Inspect the shaft shoulder and shaft keyway (Figure 18) for wear and replace, if necessary.

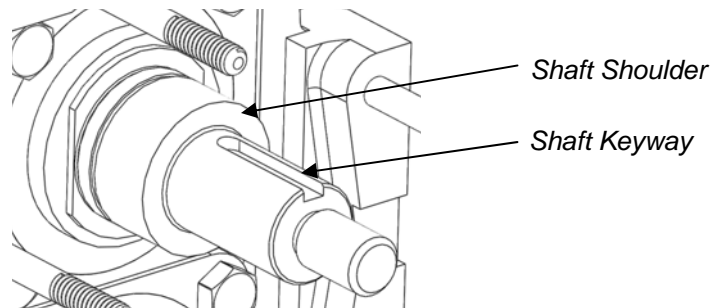

Figure 18: Shaft Inspection Points

Inspect the rotor hub and rotor keyway (Figure 19) for wear and replace, if necessary. Rotor and shaft wear at these locations is caused by extended operation with loose rotor nuts.

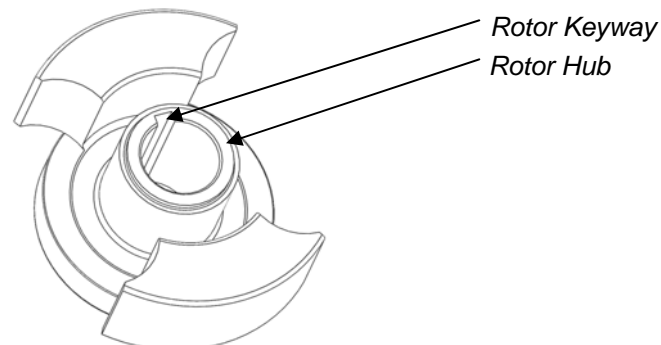

Figure 19: Rotor Inspection Points

Maintenance

Gear and Bearing Inspection

While the fluid end is disassembled, feel for gear backlash (movement between the gears) by rotating either shaft. Once turning has started the other shaft must engage (Figure 20). If gear backlash is present drain oil, remove the gear casing cover and check for wear around the gear teeth. (*drain oil first*, see page 16 for disassembly information) If evidence of gear teeth wear is present, replacement is recommended. If gear(s) are loose, check the shaft key and keyway, either may require replacement.

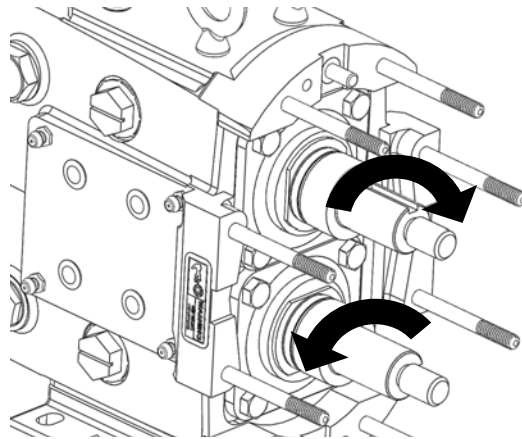

Figure 20: Check for Gear Backlash

Next, check the condition of the bearings. Do this by applying force in an up and down motion by hand on both shafts (Figure 21). Also check for any horizontal movement by pushing and pulling on the shaft. If any movement is felt the bearing may need replacing. If disassembly of the entire gear case is required, please refer to page 16 for instructions.

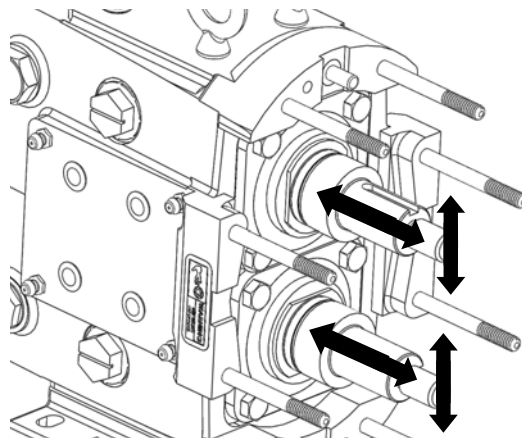

Figure 21: Check for Bearing Movement

Maintenance

Annual Maintenance

It is important to perform an annual maintenance check of the pump in addition to the preventive maintenance procedures listed on pages 13 and 14. Annual maintenance practices are as follows:

- Check the gear case bearings by measuring the shaft's radial movement with a dial indicator (Figure 22, A). If the movement is greater than or equal to the rotor-to-body clearance found on page 22 (Table 4) the bearings should be replaced.
- Remove the gear casing cover (See page 16 for disassembly information) and inspect the gears for wear and damage (Figure 22, B). Also check for backlash and looseness.
- Inspect the rotors for signs of wear and stress cracks around the areas defined in Figure 22, C. Replace, if necessary.
- Check the pump clearances detailed on page 22 to determine pump wear. Pump wear can be compensated by increasing pump speed.

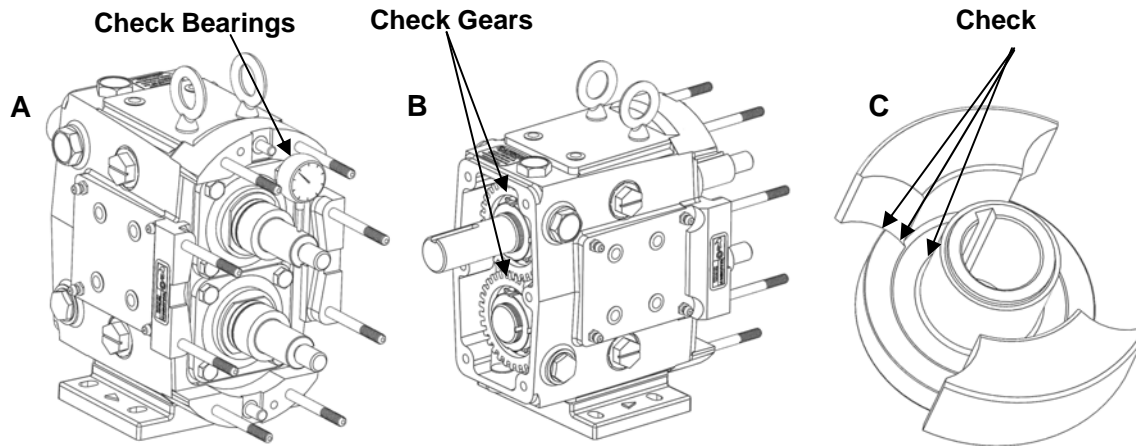

Figure 22: Annual Maintenance Checks

Cleaning

All wetted parts are designed and manufactured to be acceptable by 3A Sanitary Standards. The body, rotors, and seals can be easily disassembled and cleaned simply by removing the cover and rotor nuts. Pump disassembly information begins on page 16.

Once the fluid end is disassembled, follow standard practices for cleaning the product being pumped. If for any reason the rotor o-ring should fail and the internal threads of the rotor nut become soiled, a soft bristle brush and appropriate cleaning solution should be used to clean them. Do not use abrasive cleaning tools and chemicals. Wire brushes or pads will physically damage metal and seal parts. Pump parts should not be exposed to harsh acids for longer than necessary. Once the parts have been removed from a cleaning solution, rinse the parts so no residual deposits remain. Acids and cleaning solutions can be harmful. Take necessary steps to prevent bodily harm.

ZP3 pumps are designed for CIP (clean-in-place) capabilities ensuring that CIP solution reaches all surfaces inside the pump. The fluid velocity (typically 5 ft/sec) and differential pressure (30 psi recommended) are critical components of a correct CIP setup. For additional support, please contact the Engineering Department at Q-Pumps (+52 (442) 1033 100).

Maintenance

Pump Disassembly

1) During disassembly place all parts on a clean, protected surface with finished surfaces and seal faces facing up. Start by removing the cover nuts with an appropriate wrench (Figure 23). Tap the cover off using a soft mallet. Remove the cover o-ring and inspect it.

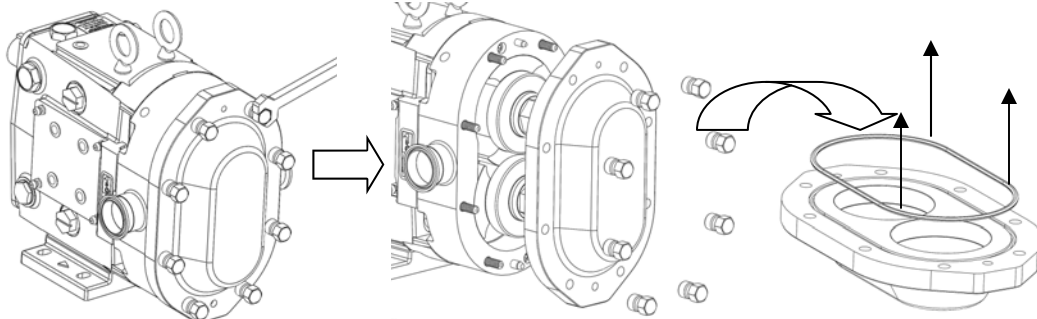

Figure 23: Removing ZP3 Cover

2) Loosen each rotor nut using the appropriate size wrench and a non-metallic wedge to keep the rotors from moving (Figure 24). Unthread each nut and disassemble the nut assembly (rotor nut, Bellville washer, and retaining o-ring).

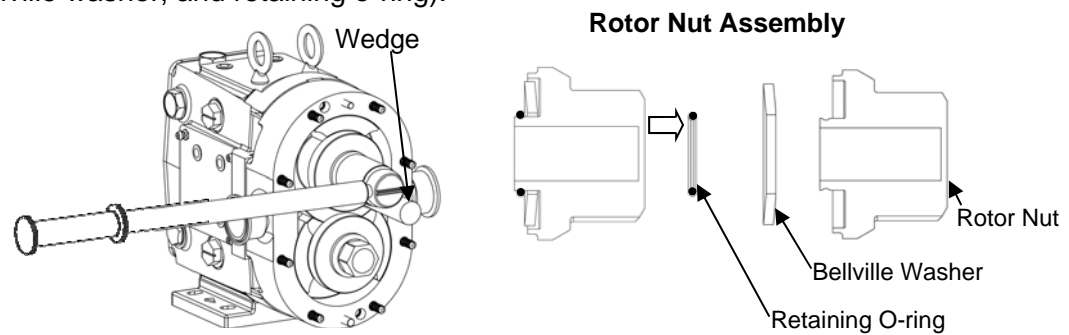

Figure 24: Rotor Removal

3) Remove the rotors by orientating them perpendicular to each other and then pulling them out. It is important to be cautious with the rotors so that they are not damaged in any way. If rotors are difficult to remove, use a nylon or wood lever to pry them out without damaging the body or the rotors. Use Figure 25 to ensure that all parts are removed.

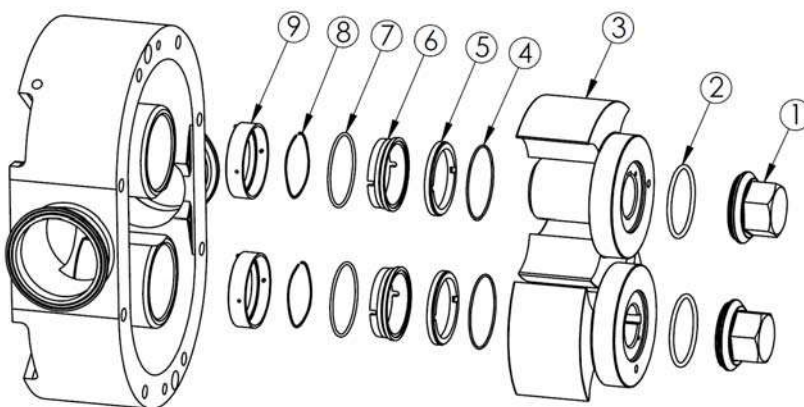

Figure 25: Exploded View Single Mechanical

	Part
1	Rotor Nut Assembly
2	Rotor Nut O-ring
3	ZP3 Rotor
4	Rotating Seal O-ring
5	Rotating Seal
6	Stationary Seal
7	Stationary Seal O-ring
8	Wave Spring
9	Seal Sleeve

Maintenance

Pump Disassembly

- 4) Remove the two body hold down bolts using the appropriate driver. Pull the pump body off by sliding it along the studs (Figure 26). If the body is stuck, use a soft mallet to tap the body. Inspect the body for excessive wear, clean, and continue on to seal maintenance. It is important to re-assemble the pump body back onto the original gear case because the shafts are shimmed for that particular body.

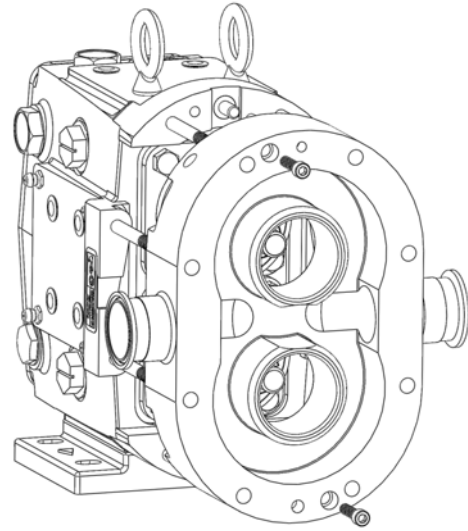

Figure 26: Removal of Pump Body

Single Seal Maintenance

- 1) Start by inserting the wave spring into the sleeve making sure that it sets below the stationary drive pins (Figure 27).

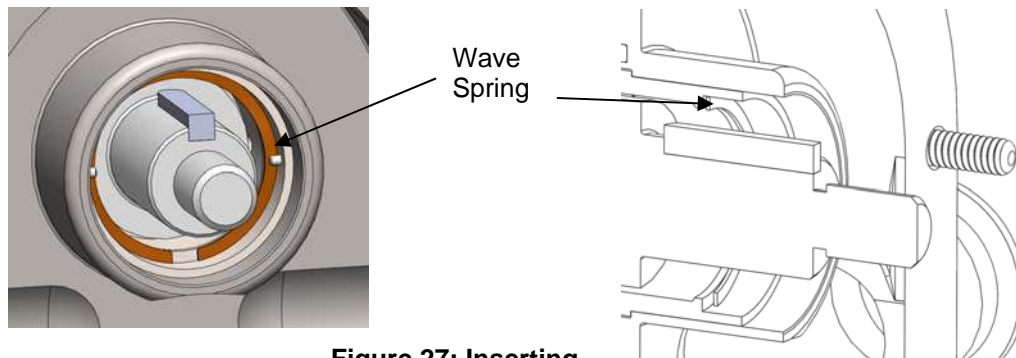

Figure 27: Inserting

- 2) Slide the stationary seal o-ring into the body hub until it seats against the top of the sleeve (previously installed). Align the slots on the stationary seal with the pins inside the hub. Press the stationary seal into the hub until it seats on the spring; there should be noticeable spring resistance when pushing on the seal.

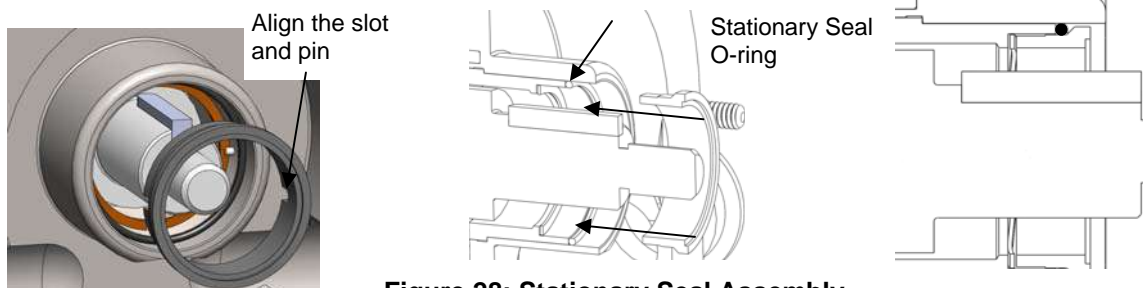

Figure 28: Stationary Seal Assembly

Maintenance

Single Seal Maintenance

3) Next install the rotating o-ring onto the rotating seal by stretching it (not rolling) onto the rotating seal (Figure 29).

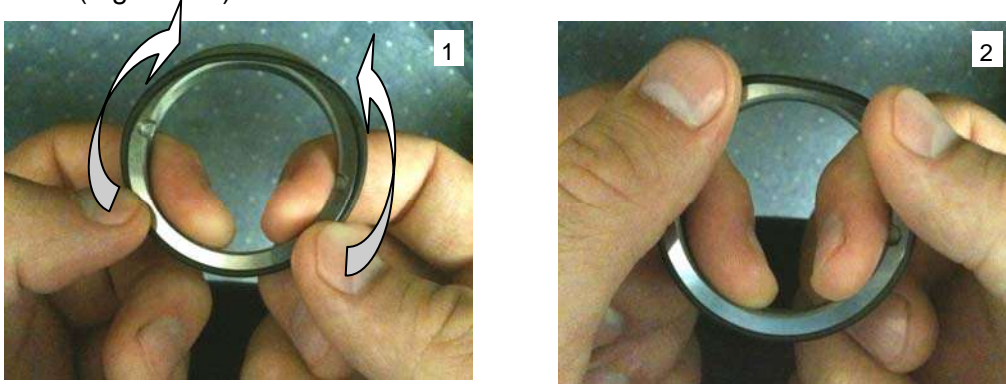

Figure 29: Installing the Rotating O-ring

4) Slide the rotating seal onto the rotor hub (Figure 30) making sure to align the slots on the seal to the drive pins in the rotor. Press the seal down until it seats inside of the rotor.

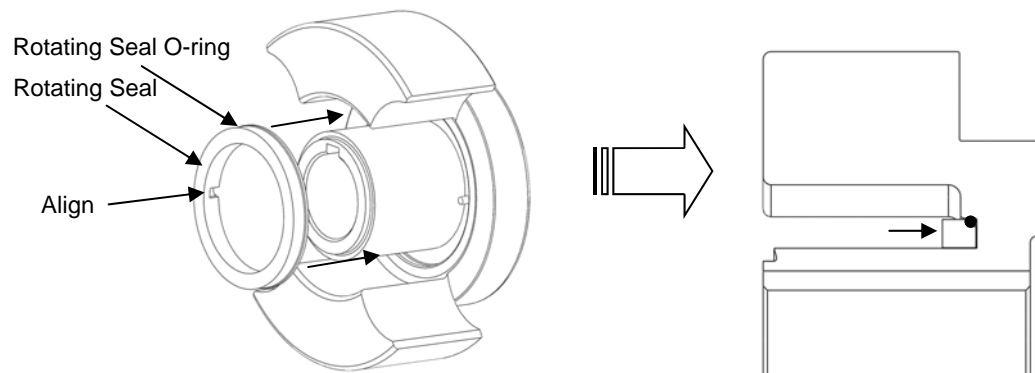

Figure 30: Inserting Rotating O-ring

5) Insert a rotor key in the keyway on the shaft. Slide the rotors onto the shafts until they seat against the shaft shoulder (Figure 31).

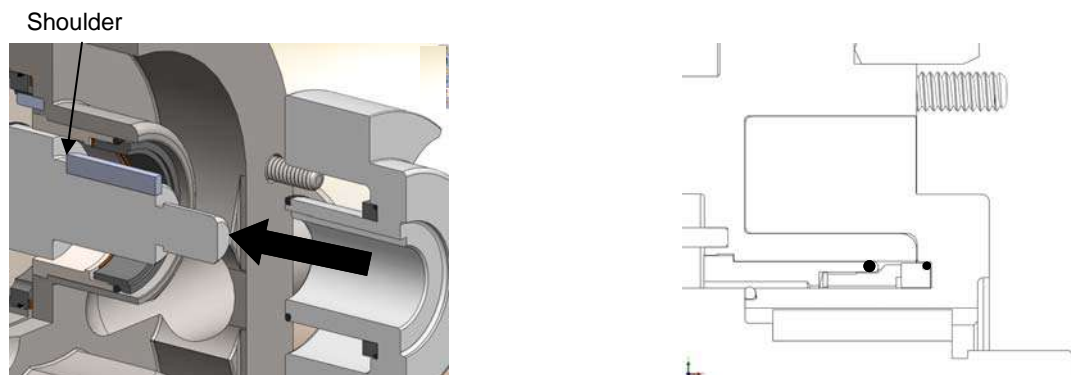

Figure 31: Rotor Assembly

Maintenance

Single Seal Maintenance

- 6) Install the Bellville washers in the rotor nuts in the orientation shown and hold them in place using the small retaining o-rings (Figure 32). Install a rotor nut o-ring before threading the nut onto the shaft.

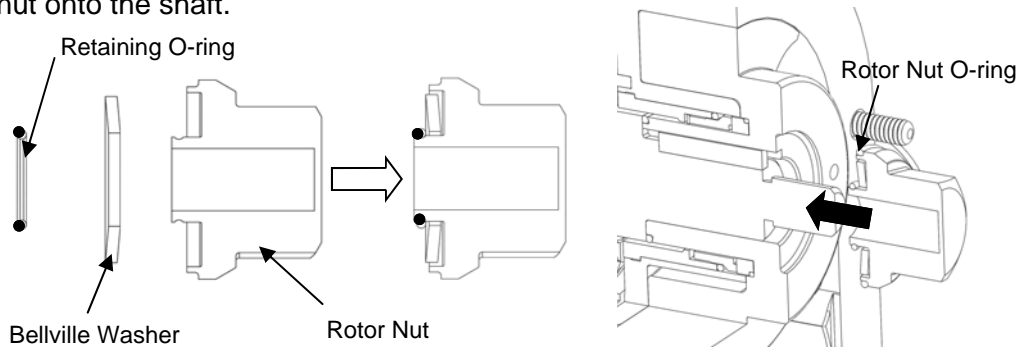

Figure 32: Rotor Nut Assembly

- 7) Thread the nut onto the shaft and tighten it down using the appropriate wrench and a non-metallic wedge to hold the rotor in place (Figure 33). Reference page 23 for rotor nut torque values. Orientate the rotors as seen in Figure 33 and **Always** tighten the first rotor positioned under the overlap of the opposing rotor. Repeat with the second rotor in the same orientation.

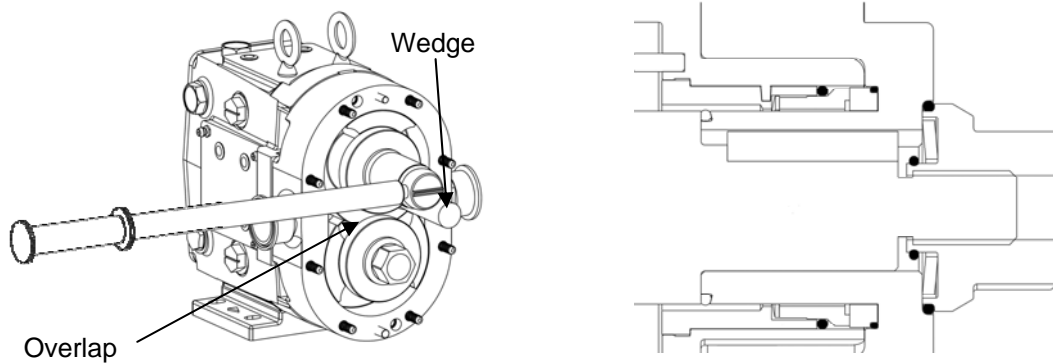

Figure 33: Rotor Assembly

- 8) Install a new cover o-ring and slide the cover over the studs making sure that the dowels in the body are aligned with the correct dowel holes in the cover (Figure 34). Visually inspect to ensure that the cover o-ring remained in place. Turn the cover nuts (clockwise) by hand and fully tighten them using the appropriate wrench. Tighten the cover nuts in an opposing manner, as seen on Figure 34, so that the cover is evenly tightened to the body.

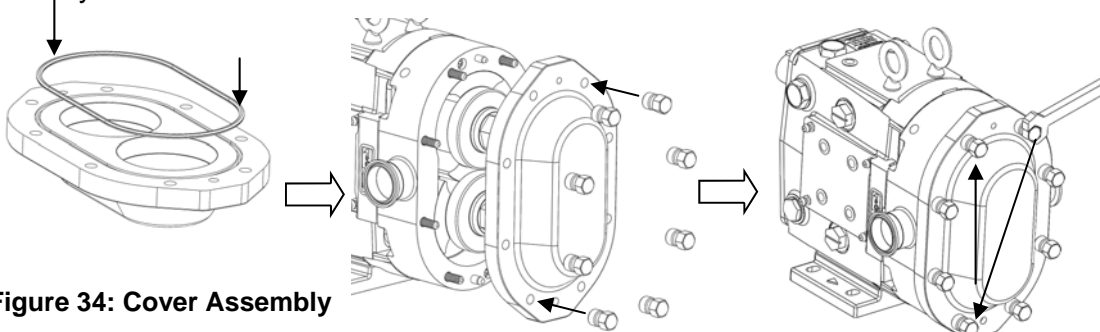

Figure 34: Cover Assembly

Maintenance

Double Seal Maintenance

Disassembly:

Use caution not to damage the seals during removal.

- 1) Remove the Inner stationary seals from the pump body (Figure 35, item 61).
- 2) Remove the wave springs and stationary o-rings from the stationary seals.
- 3) Slide the seal seats from each shaft, and remove the seal seat o-ring from the shaft.

Figure 35

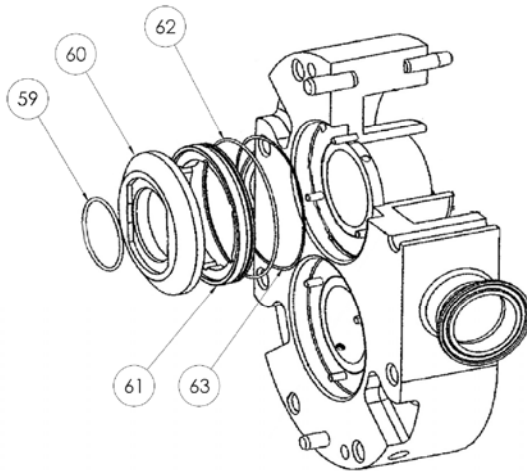

ITEM NO.	DESCRIPTION	QTY.
59	SEAL SEAT O-RING	2
60	SEAL SEAT (DOUBLE)	2
61	STATIONARY SEAL (DOUBLE)	2
62	OUTER SEAL O-RING	2
63	WAVE SPRING, OUTER SEAL	2

Assembly:

Clean both shaft ends and the body before assembling. Apply a light film of lubricant to NEW seal seat o-rings and insert them on the shaft's slot. Slide the seal seat onto the shaft by pushing it against the shaft shoulder making sure to align the drive flats on seal seat and shaft (Figure 36).

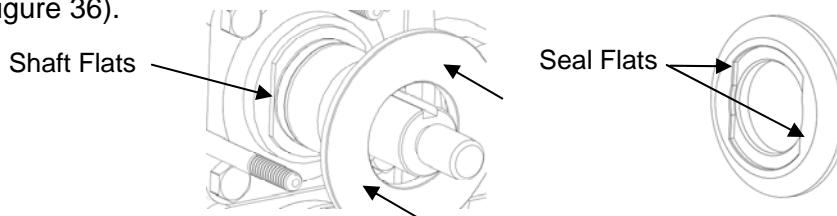

Figure 36: Aligning Flats

Apply a light film of lubricant to NEW inner stationary o-rings and install them on the inner stationary seals. Place the inner wave spring into the body and install the inner stationary seal into the seal groove (Figure 37). Make sure the seal stop pins are aligned with the notches on the inner stationary seal. For double seals, apply a light film of lubricant to NEW outer stationary o-rings and install them on the outer stationary seals. Place the outer wave spring into the body and install the outer stationary seal in the seal groove (Figure 37). Check that the seal stop pins are aligned with the notches on the outer stationary seal.

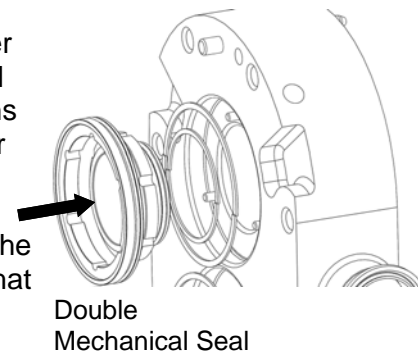
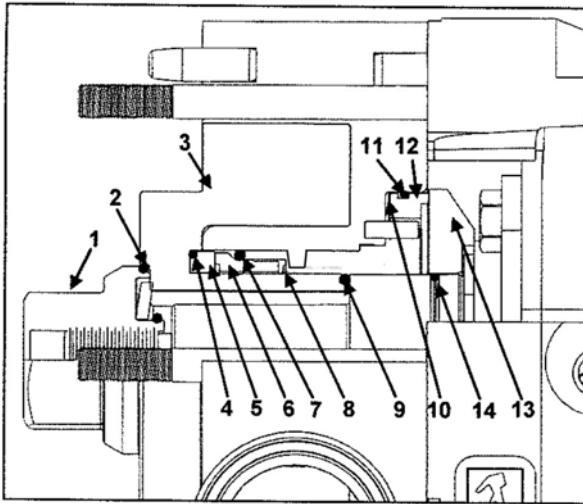

Figure 37: Installing Stationary Seals

Maintenance

Seal Cutaways



	Part
1	Rotor Nut Assembly
2	Rotor Nut O-Ring
3	ZP3 Rotor
4	Rotating Seal O-Ring
5	Rotating Seal
6	Stationary Seal
7	Stationary Seal O-Ring
8	Wave Spring
9	Rotor Hub O-Ring
10	Wave Spring, Outer Seal
11	Outer Seal O-Ring
12	Stationary Seal (Double)
13	Seal Seat (Double)
14	Seal Seat O-Ring

Specific parts for Double Mechanical Seals (9-14)

Seal Flush

For pumps with double seals, connect seal flushing before operation. Operation of the pump without proper flushing will **damage** seal faces. Flushing connections are typically 1/8" female NPT with one side being the inlet and the other the discharge. Flush from the bottom to the top, using the lower connection as the inlet and the upper connection as the discharge. This ensures that air is removed from the flush line with the flush area completely flooded (Figure 38). Flush flow rate should be 1/4 GPM (30 psi max pressure). For high temperature applications flush flow may be increased to remove excess heat.

ZP3 is capable of a barrier pressure *no more than* 10-15 psi above the process pressure. Keep in mind a small amount of the barrier fluid will enter the pumped liquid, therefore the barrier fluid must be compatible with the product.

**Maximum Barrier Pressure is 100psi*

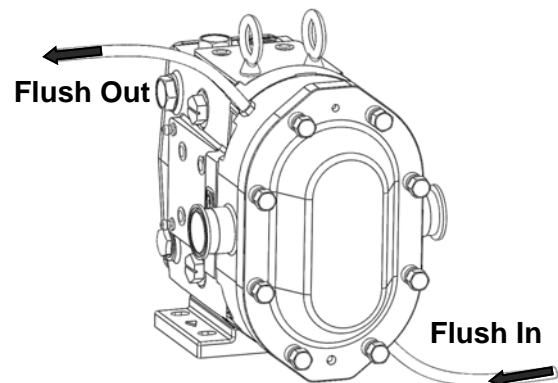

Figure 38: Proper Flushing for ZP3 Double Seal

Maintenance

Pump Clearances

The performance of a ZP3 is based on the tight clearances between the pump body and the rotors. These clearances are critical to ensure the pump performs up to the system requirements. The clearance between the rotor and the back face of the body is referred to as the backface clearance. Other clearances are shown in Figure 39 and should be in accordance to Table 4. Use shims and a depth micrometer to measure the clearances.

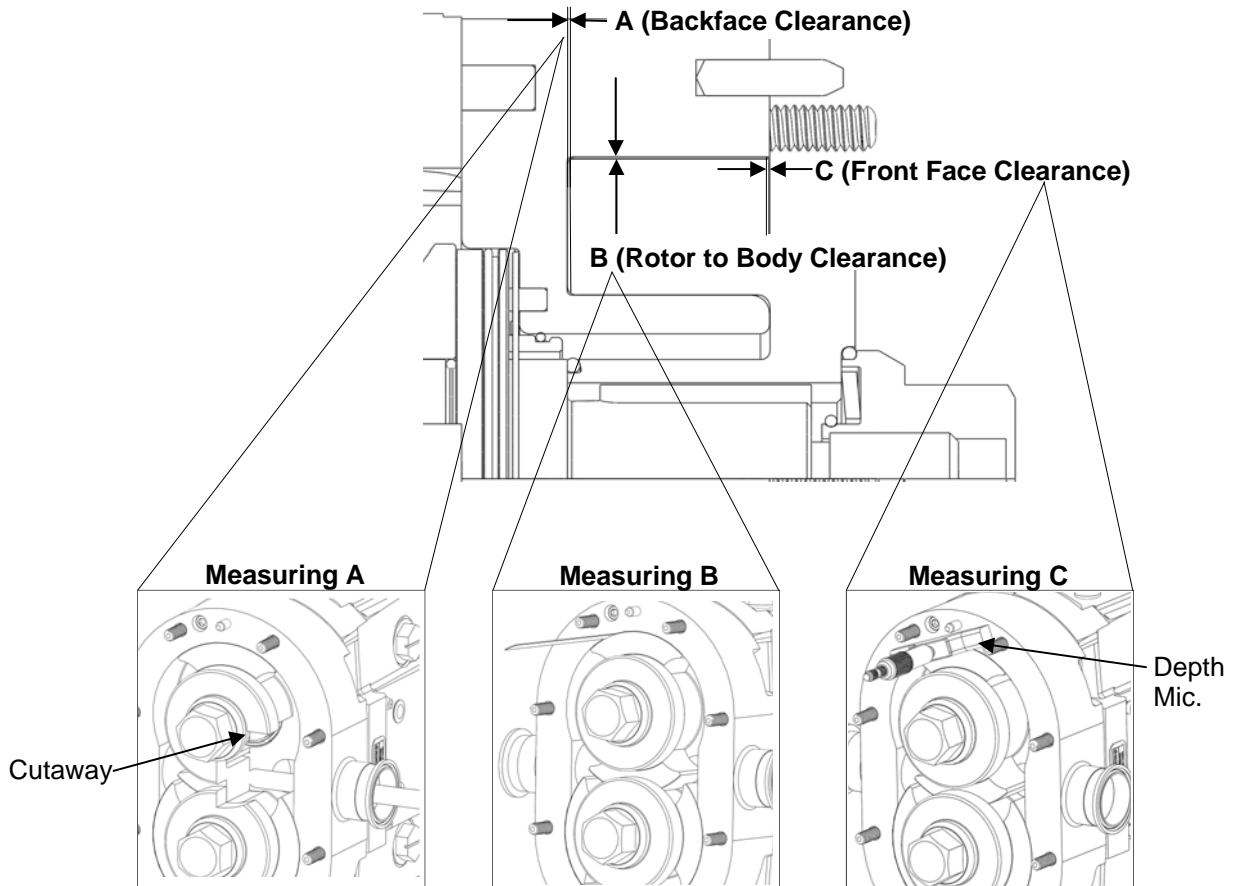

Figure 39: Critical Pump Clearances

Table 4: Critical Pump Clearance Dimensions (Standard Rotors)

ZP3 Model	A (Backface Clearance)		B (Rotor to Body Clearance)		C (Front Face Clearance)	
	Inch	mm	Inch	mm	Inch	mm
6, 15, 18	.002	.05	.002	.05	.005	.13
30, 34, 40	.002	.05	.002	.05	.005	.13
45, 60, 64	.004	.10	.005	.13	.008	.20
130, 134	.004	.10	.005	.13	.008	.20
180, 184, 220, 224	.005	.13	.006	.15	.008	.20
210, 214, 320, 324	.005	.13	.010	.25	.011	.28

Maintenance

Pump Assembly

1) Make sure all seal components are installed by following “Seal Assembly” instruction provided on page 17. Ensure all dowels are in place and that all parts including body, rotors, and rotor nuts are clean and free of foreign matter. Slowly slide the body over the gear case studs and shafts, ensuring the seals are kept in place and not damaged (Figure 40). Install the two hold down bolts and tighten the body against the gear case to ensure the dowels are engaged. Rotate the shafts to make sure there is no interference with the seals.

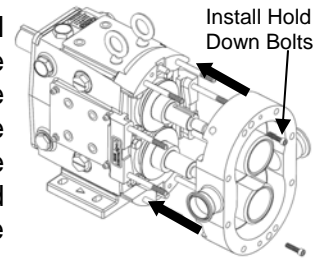

Figure 40: Installing Pump Body

2) Insert rotor key in the keyway on the shaft. Install a new rotor hub o-ring on the rotor hub and align the rotor keyway to the key in the shaft (Figure 41, A). Slide the rotor on until it seats against the shaft. Install the Bellville washer in the rotor nut and hold it in place using the small retaining o-ring (Figure 41, B). Place one nut on at a time, tightening them down using the appropriate wrench and a non-metallic wedge to hold the rotor in place (Figure 41, C). See Table 5 for required torque values. Repeat with the second rotor.

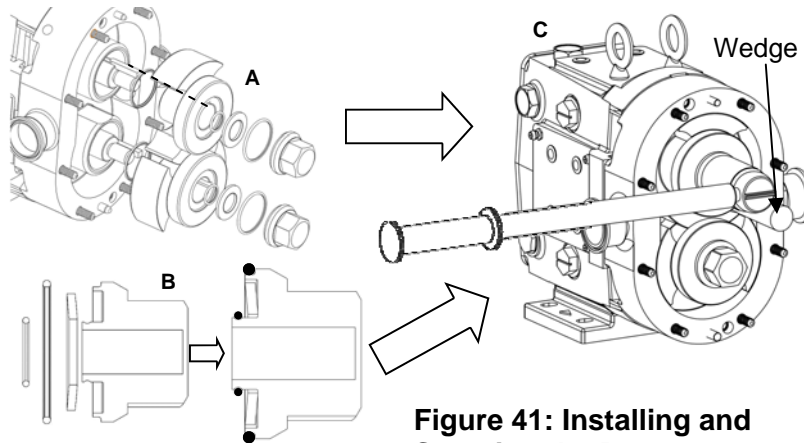

Figure 41: Installing and Securing the Rotor

Table 5: Recommended Rotor Nut Torque Values

ZP3 Model	Torque	
	ft-lbs	N-m
6, 15, 18	50	68
30, 34, 40	120	163
45, 60, 64, 130,134	250	339
180, 184, 220, 224	325	441
210, 214, 320, 324	375	508

3) Install the new cover o-ring and slide the cover over the studs making sure that the dowels in the body are aligned with the correct dowel holes in the cover (Figure 42). Visually inspect to ensure that the cover o-ring remained in place. Turn the cover nuts (clockwise) by hand and fully tighten them using the appropriate wrench. Tighten the cover nuts in an opposing manner as seen on Figure 42, so that the cover is evenly tightened to the body.

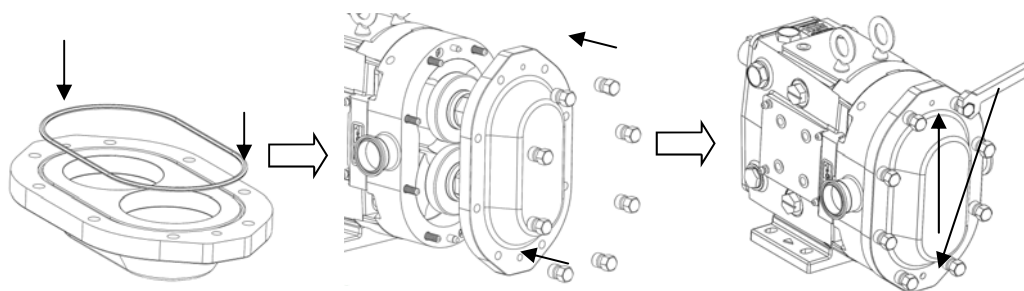

Figure 42: Cover Assembly

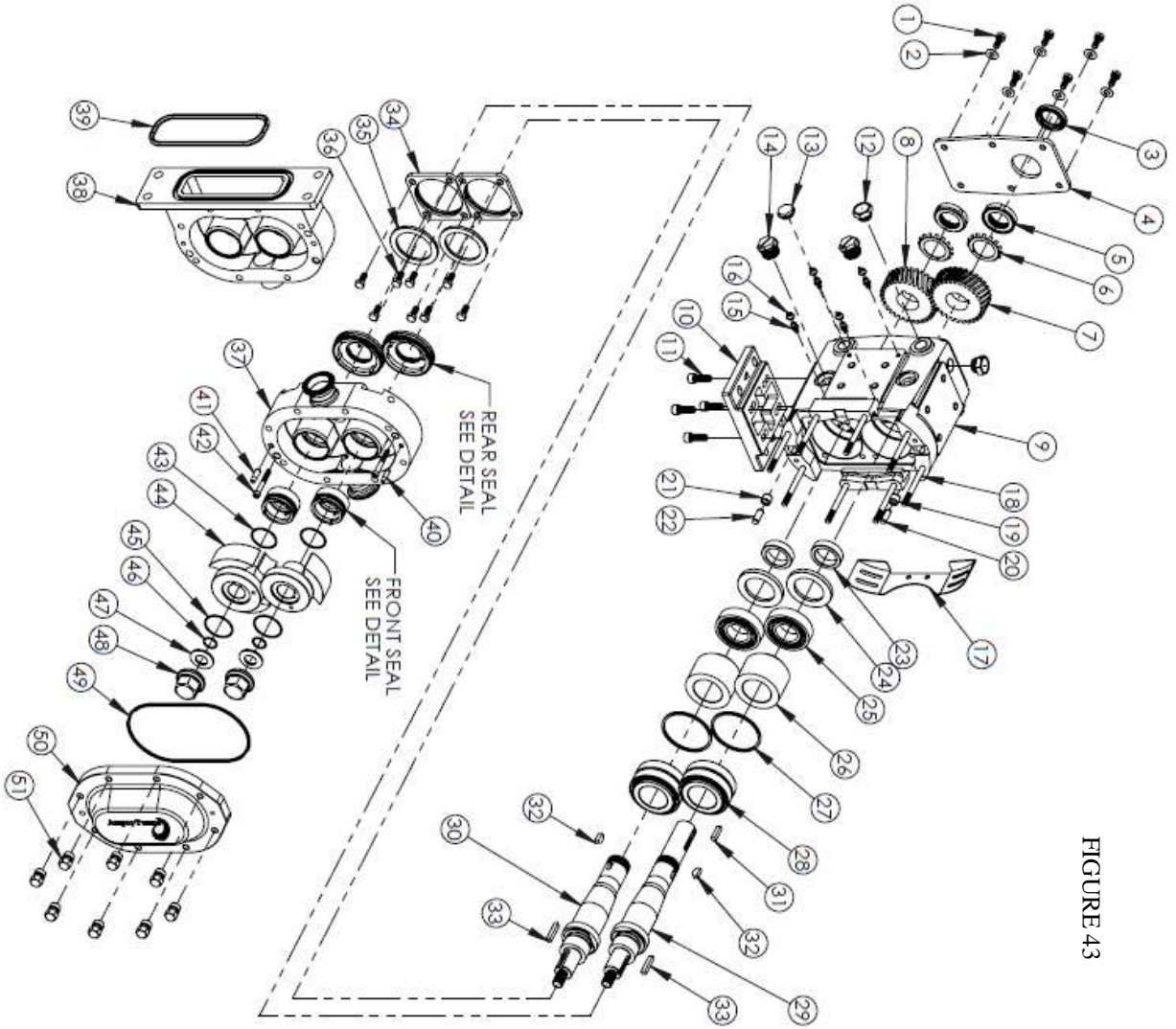

FIGURE 43

Q-PUMPS PARTS BREAKDOWN		
ZP3 SERIES		
ITEM NO.	QTY.	DESCRIPTION
1	6	GEAR CASE COVER BOLT
2	6	GEAR CASE COVER FLAT WASHER
3	1	GEAR CASE COVER OIL SEAL
4	1	GEAR CASE COVER
5	2	GEAR LOCKNUT
6	2	GEAR LOCK WASHER
7	1	GEAR DRIVESHAFT
8	1	GEAR LAYSHAFT
9	1	GEAR CASE
10	1	FOOT PAD
11	4	FOOT PAD BOLT
12	5	PLUG, OIL DRAIN/FILL
13	1	PLUG, OIL LEVEL SIGHT
14	4	PLUG, CLEANOUT
15	8	GREASE FITTING
16	8	GREASE FITTING COVER
17	2	SHAFT GUARD
18	2	STUD, GEAR CASE / COVER
19	1	DOWEL BUSHING, UPPER GEAR CASE
20	1	DOWEL PIN, UPPER GEAR CASE
21	1	DOWEL BUSHING, LOWER GEAR CASE
22	1	DOWEL PIN, LOWER GEAR CASE
23	2	SPACER, GEAR / REAR BEARING
24	2	OIL SEAL, REAR
25	2	BEARING, REAR
26	2	SPACER, REAR / FRONT BEARING
27	2	BEARING SHIM KIT
28	2	BEARING, FRONT
29	1	DRIVESHAFT
30	1	LAYSHAFT
31	1	DRIVE KEY
32	2	GEAR KEY
33	2	ROTOR KEY
34	2	BEARING RETAINER
35	2	BEARING RETAINER OIL SEAL
36	8	BEARING RETAINER BOLT
37	1	ROTOR BODY, STD.
38	1	ROTOR BODY, RECT. FLANGE
39	1	RECT. FLANGE INLET GASKET
40	1	DOWEL PIN, UPPER ROTOR BODY
41	1	DOWEL PIN, LOWER ROTOR BODY
42	2	ROTOR BODY RETAINING BOLT
43	2	O-RING, ROTOR SEAL FACE
44	2	ROTOR
45	2	O-RING, ROTOR NUT
46	2	O-RING, RETAINER
47	2	BELLEVILLE WASHER
48	2	ROTOR NUT
49	1	O-RING, COVER
50	1	ROTOR BODY COVER
51	8	ROTOR BODY COVER NUT

Maintenance

Gear Case Maintenance



WARNING: Before servicing pump or motor, DISCONNECT the energy source to the pump. This will prevent accidental start-up and serious injury.

CAUTION: SHUT OFF product supply to the pump and drain the pump before disconnecting piping and disassembly.

Disassembly

1) Remove the pump head as described on page 16 (Pump Disassembly). Remove the bottom oil plug and drain the oil from the gear case (remove oil fill plug for faster drain). Remove the six hex head cap screws and washers from the gear case cover and slide the cover off the drive shaft (Figure 44). If the cover is stuck, use a soft mallet to tap around the edges until it breaks free. Using a straight edge remove the liquid gasket used to seal the cover to the gear case. Remove and discard the oil seal from the cover using an arbor press.

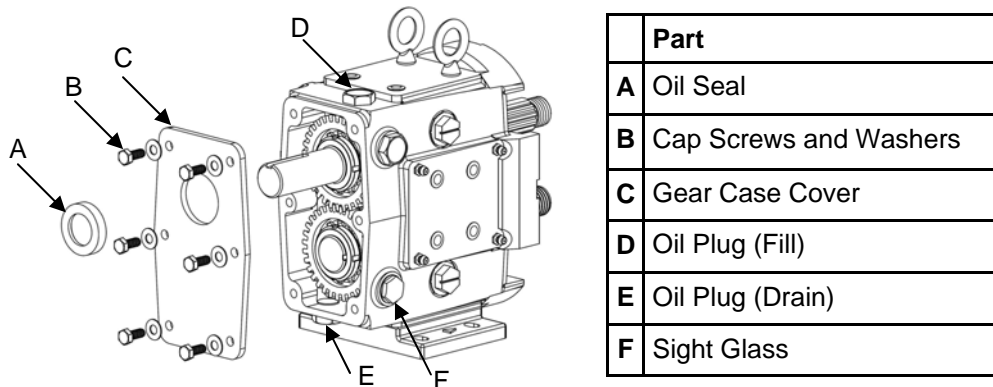

Figure 44: Gear Case Disassembly (Gear Case Cover)

2) Using a hammer and a punch, bend the tabs straight on the lock washers (Figure 45). Use a wedge (wood or plastic) to keep the shafts from turning while removing the lock nuts (Figure 46). Using a spanner wrench or the nut removal tool (available from Q-Pumps), remove the gear lock nuts. Slowly remove the gears from the shafts. Remove the gear keys and gear spacers from the shafts.

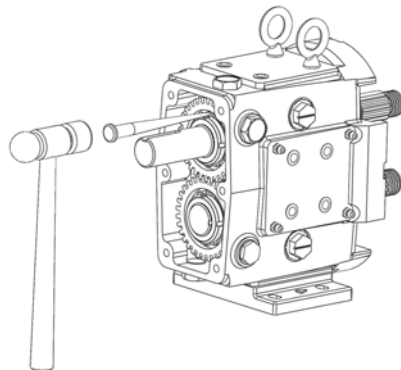

Figure 45: Bending Tabs on Lock Washers

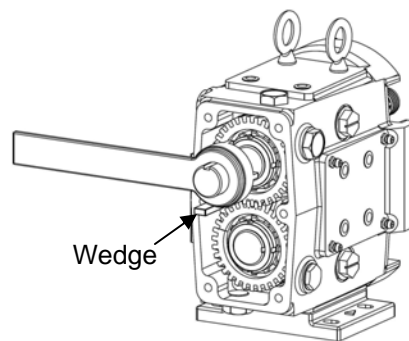

Figure 46: Removing Lock Washers

Maintenance

Gear Case Maintenance

3) To prevent damage to the shafts, wrap the keyway and rotor nut threads with tape (Figure 47, A). Any damage to the shaft or threads may require the shaft be replaced. Remove the cap screws holding the bearing retainers in place and slide both bearing retainers off the shaft (Figure 47, B). If they are stuck, use a flat head screw driver as a wedge to pry them from the gear case or leave them in place and when the shafts are removed they will press off with the shafts. Using a straight edge, remove the liquid gasket used to seal the bearing retainer to the gear case.

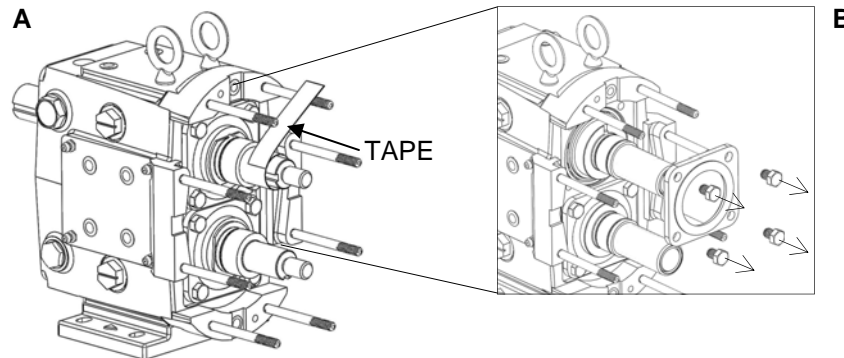

Figure 47: Tape Shafts and Remove Bearing Retainers

4) Set the gear case in a press with the fluid end side facing down (Figure 48). Use a wooden block to protect the shafts from hitting the ground when pushed out. Once the protective block is in place, push the shafts out of the gear case. Reference Table 6 for the required force (in tons) needed to press the shafts out of the gear case.

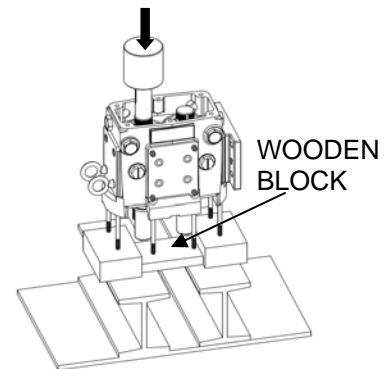

Figure 48: Pressing Shafts From Gear Case

Table 6: Required Force to Remove/Install shafts

ZP3 Model	6, 15, 18	30, 34, 40	45, 60, 64, 130 134	180, 184, 220, 224	210, 214, 320, 324
In (Tons)	.25	.25	.50	.50	.50
Out (Tons)	.50	.50	1.00	1.00	1.00

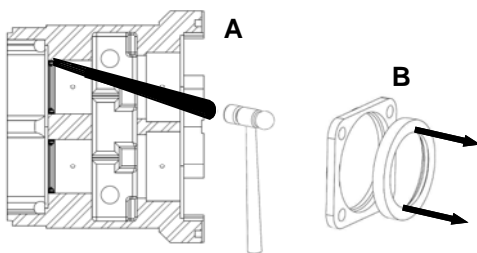

Figure 49: Removing Oil Seals

5) Remove all the shaft shims from the gear case and label which shaft and bore they came from. If the shafts are to be reused, they will need to be reinstalled with the original shims. Failure to do so could result in damage and misalignment in the pump body. Remove and discard the rear oil seals from the back of the gear case. Use a long, non-metallic rod and a soft mallet to punch the seal out from the front side (Figure 49, A). Remove and discard the front bearing seals from the bearing retainers by pressing them out (Figure 49, B). Clean the bearing retainers as they will be reused. Clean excess grease and sludge inside of the gear case before reassembling.

Maintenance

Gear Case Maintenance

6) Using a press and a V-block, remove the front and rear bearings along with the bearing spacer. To prevent damage to the shafts make sure that both ends are protected (Figure 50). Reference Table 7 for the required force (in tons) needed to press the bearings off the shafts.

Table 7: Force Required to Press Bearings

ZP3 Model	Front Bearings		Rear Bearings	
	On (Tons)	Off (Tons)	On (Tons)	Off (Tons)
6, 15, 18	.50	1.00	.50	1.00
30, 34, 40	.50	1.00	.50	1.00
45, 60, 64, 130,134	2.00	5.00	3.00	5.00
180, 184, 220, 224	5.00	15.00	5.00	15.00
210, 214, 320, 324	5.00	20.00	5.00	20.00

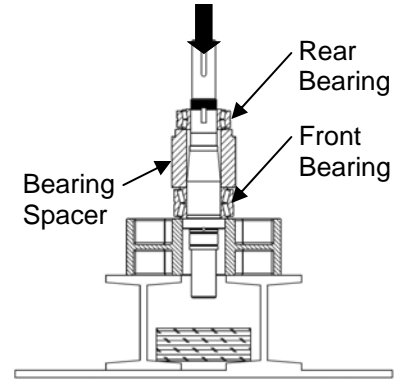

Figure 50: Removing Bearings and Sleeve From Shaft

Assembly

1) Clean all reusable parts prior to reassembly. Apply a light coat of lubricant on the shaft area where the front bearing will sit. Position the shaft upright in the press with the rotor end facing down (Figure 51, Drawing 1). Open the new front bearing assembly and be sure not to interchange any parts. All bearings are manufactured as sets and assembled to have a precise overall length. Place the front bearing over the shaft along with the bearing spacer (Figure 51, Drawing 2). Make sure the bearing and spacer are aligned before pressing them on. Reference Table 5 for the required force (in tons) needed to press the bearings on to the shafts. Using a sleeve that rests on the bearing spacer and rides over the shaft, press the bearing on until it seats against the shaft shoulder. A shim can be used to ensure that the bearing is fully rested on the shaft shoulder (Figure 51, Drawing 3).

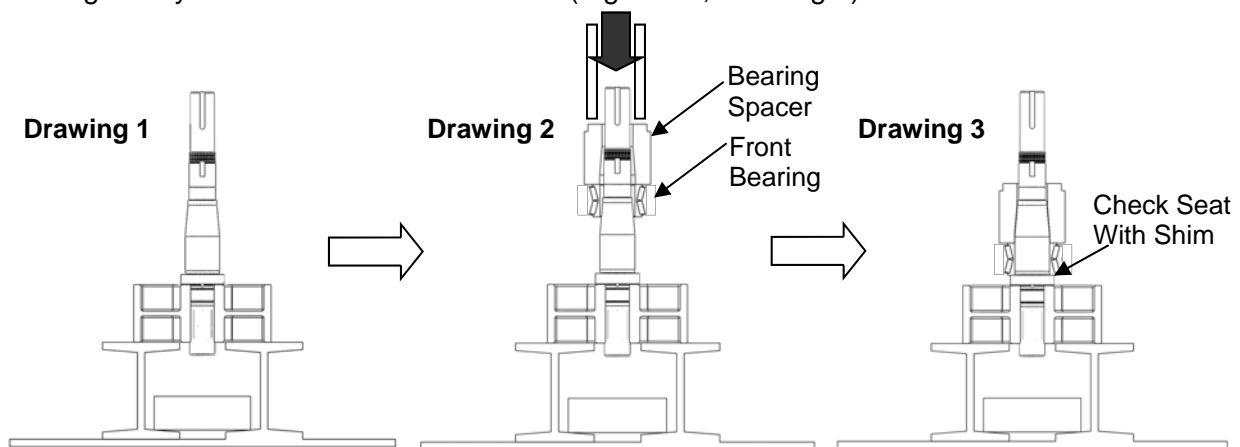

Figure 51: Pressing Front Bearing onto Shaft

Maintenance

Gear Case Maintenance

2) Single ball bearings are used for the rear bearings in models ZP3 6, ZP3 15, ZP3 18, ZP3 30, and ZP3 34 and will require a light press to install. Tapered roller bearings are used for all other models and will be pressed on similar to the front bearings.

- For pump models with single ball bearings apply a light coat of lubricant on the shaft. Open the new rear bearing assembly and place it over the shaft above the bearing spacer with the shielded side of the bearing facing the spacer (Figure 52, Drawing 1). Press the bearing on by pressing only on the inner race.
- For pump models with tapered roller bearings, apply a light coat of lubricant on the shaft. Open the new rear bearing assembly and do not interchange any parts. Place the rear bearing over the shaft above the bearing spacer (Figure 52, Drawing 2). Reference Table 7, page 27 for the required force (in tons) needed to press the bearing onto the shaft. Using a sleeve that rests on the inner cone of the bearing and rides over the shaft, press the bearing on until it seats against the spacer.

Make sure the bearing is rested on the bearing spacer using a shim (Figure 52, Drawing 3).

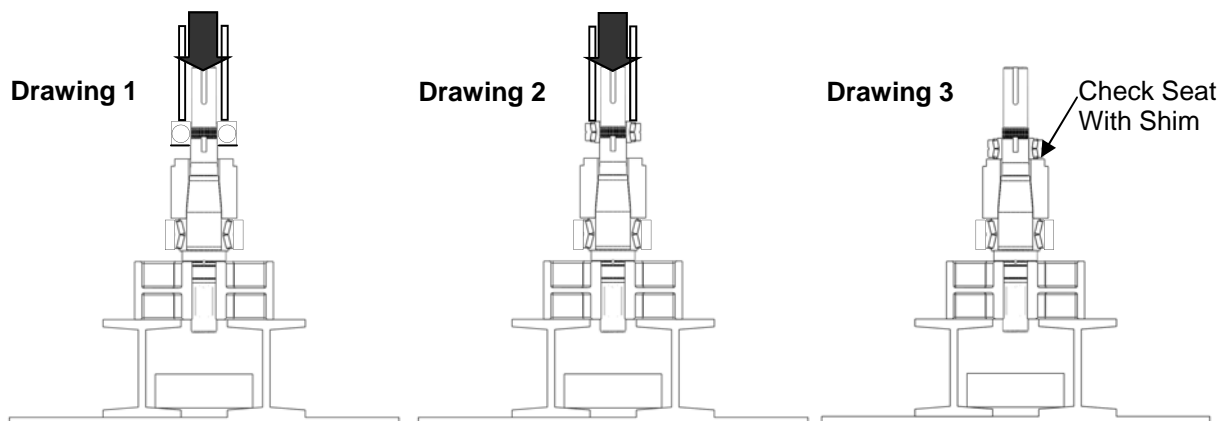
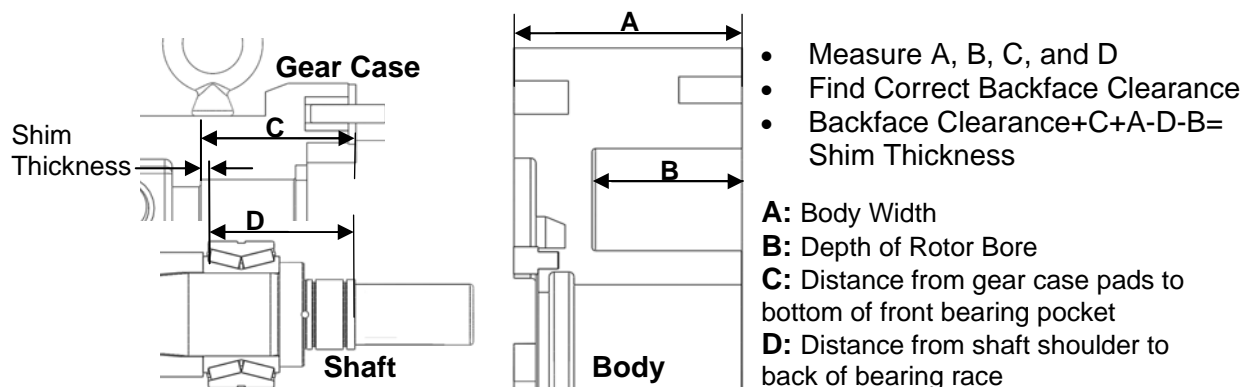

Figure 52: Pressing Rear Bearing onto Shaft

3) Shims located on the shaft, behind the front bearing, control the backface clearance of the pump; the space between the body and the rotor. If neither the shafts nor bearings are being replaced, use the shims (if properly marked) removed at disassembly and reuse making sure they are installed in the correct bores. If replacing shafts or bearings, a process of calculating the required shims is necessary. Use Figure 53 and the following equation to calculate. To find the correct backface clearance see Table 4, page 22.



Maintenance

Gear Case Maintenance

4) Set the gear case on a press with the fluid end side facing up. Place the required thickness of shim stock so it sits on the shoulder of the front shaft bore of gear case. Apply lubricant to the outside of the bearings. Place shaft assembly (one shaft at a time) in the gear case with the rotor end facing up. Making sure that the drive and the short shafts are in the correct bores, press the shafts into the gear case until bearings are fully seated (Figure 54). See Table 6 on page 26 for the required force.

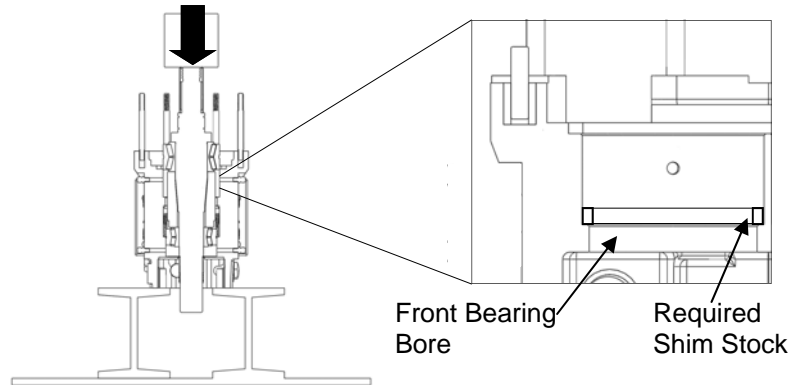

Figure 54: Pressing Shafts into Gear Case

5) Once the shafts are pressed into the gear case, install the bearing retainers to hold the shafts in place temporarily (do not install liquid sealant). Ensure there is proper clearance between the retainer and the gear case, as seen in Figure 55. Place the body on the gear case, making sure it is seated correctly. Assemble the rotors into the body and tighten down using the rotor nuts. Measure dimensions A, B, and C seen in Figure 56 and refer to Table 4 (page 22) to verify the clearances. If clearances are not correct, the shafts must be removed and the shims will need to be adjusted. If the clearances are correct, remove the rotors and body.

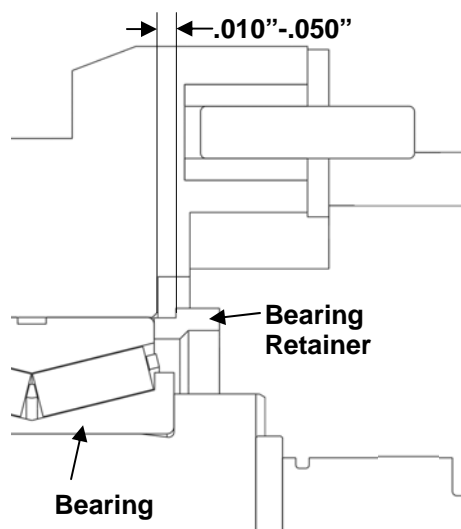

Figure 55: Bearing Retainer Clearance

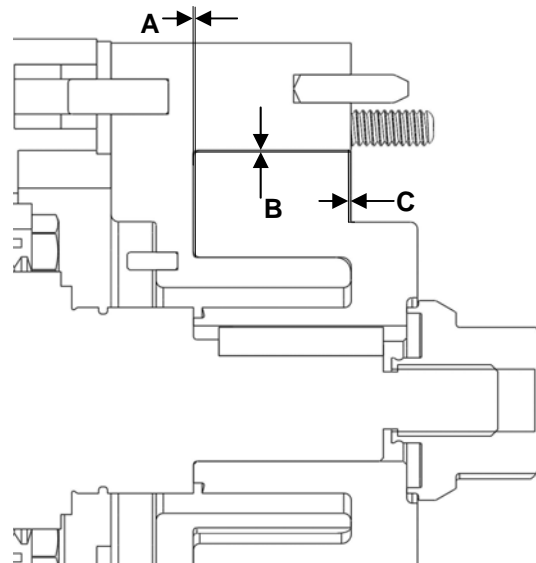

Figure 56: Important Clearances

Maintenance

Gear Case Maintenance

6) Once the correct backface clearance is achieved, fill all bearings with grease through the fittings on the mounting pads until grease is noticeable around the bearing assemblies. The shafts should be rotated during this initial greasing to distribute the grease evenly. Apply a light film of lubricant to the inside and outside diameters of the oil seals and install them into the bearing retainers. Apply a silicone sealant to the outside flanges on the bearing retainer (Figure 57). Once the silicone sealant is applied, install the bearing retainers onto the gear case.

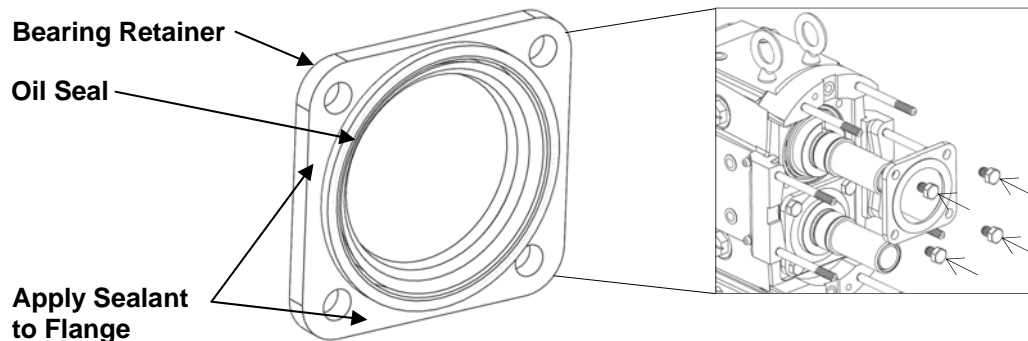

Figure 57: Bearing Retainer Installation

7) Apply a light film of lubricant to the inside and outside diameters of the rear oil seals, and install them into the back of the gear case with the spring side facing outward toward the gear. Install the gear spacers onto the shaft and place the gear keys into the shaft key slots (Figure 58).

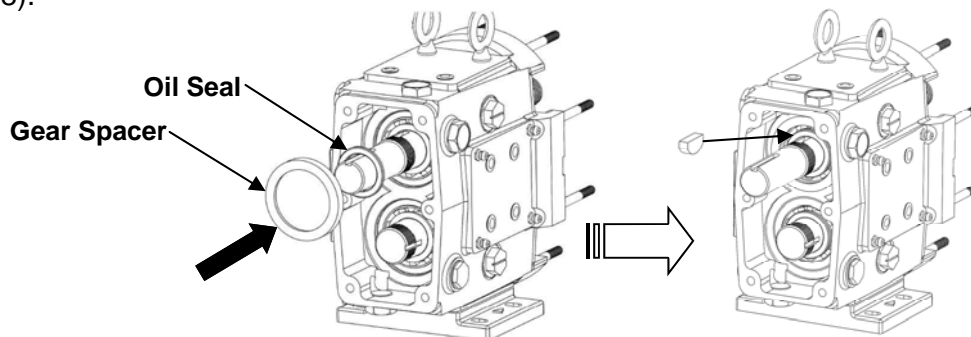

Figure 58: Rear Oil Seal and Gear Key Installation

8) Once the gear keys are installed, orientate the shafts so that the keyways on the drive shaft are pointing in the 12 o'clock direction (Figure 59, A). Slide the right-handed gear with the single punch mark onto the drive shaft. Slide the second gear with two punch marks on the short shaft. To time the gears, align them so that the single punch mark falls between the two punch marks on the opposite gear (Figure 59, B).

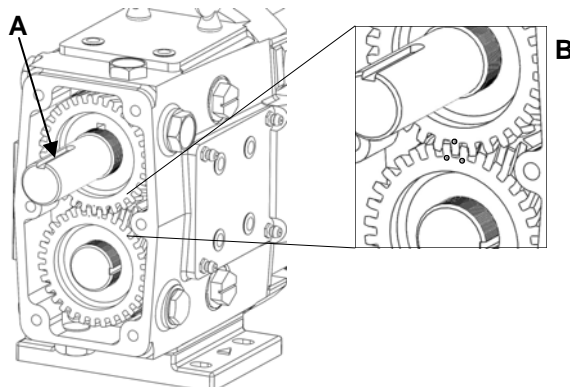

Figure 59: Installing Gears with Correct Timing

Maintenance

Gear Case Maintenance

9) Install the lock washers on the shaft by aligning the tab inside the lock washer with the slot in the shaft (Figure 60, A). Lubricate the threads of the lock nuts and thread them on the shafts. Using a spanner wrench, tighten them to the specified torque in Table 8. Use a wedge (wood or plastic) between the gear teeth to keep the shafts from turning while tightening the lock nuts (Figure 60, B).

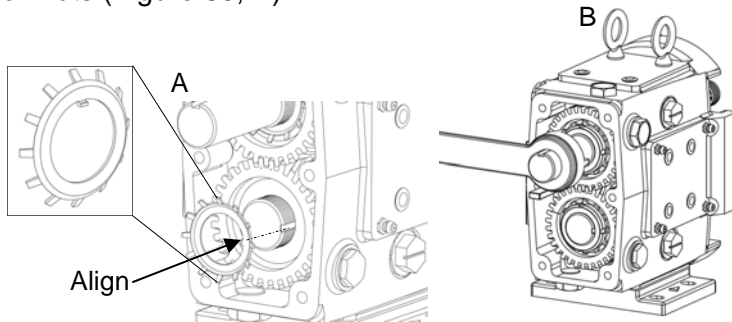

Figure 60: Installing Lock Washer and Lock Nut

Table 8: Recommended Lock Nut Torque Values

ZP3 Model	Torque	
	ft-lbs	N-m
6, 15, 18	75	102
30, 34, 40	100	136
45, 60, 64, 130, 134	140	190
180, 184, 220, 224	230	312
210, 214, 320, 324	320	434

Secure the nut in place by bending the locking tabs on the lock washer into the lock nut slots (Figure 61).

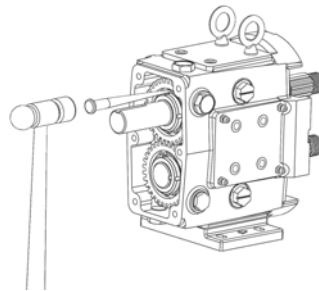

Figure 61: Bending Tabs on Lock Washer

10) Apply a light film of lubricant to the inside and outside diameters of the gear case cover oil seal. Using a press, install the oil seal into the back cover so that it is flush with the outside of the back cover and the spring is facing the gears. Apply a silicone sealant to the edges on the back of the gear case making sure there are no gaps. Slide the back cover onto the gear case, making sure that the shaft is centered on the oil seal, and secure it with the retaining bolts (Figure 62). It is important not to cut the oil seal on the shaft keyway; tape may be used to cover any sharp edges on the shaft. Install the oil plugs and fill the gear case with the recommended amount of oil using Table 3 on page 12.

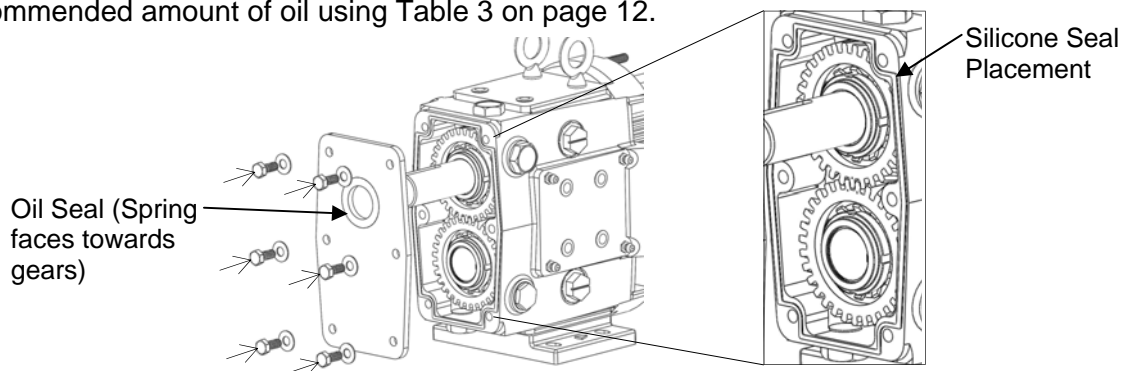

Figure 62: Installing Gear Casing Back Cover

Options

Vented Cover (Pressure Relief)

The vented cover option is an internal pressure and flow control which works independent of flow (rotational direction). The complete assembly can be seen in Figure 63. The relief pressure is set with the adjustment screw and may require in-line pressure gauges for calibration. The vented cover is designed for COP (Clean-Out-of-Place) practices.

Part	Part
1 Vented Cover	5 Spring
2 Rubber Diaphragm	6 Cover Nut
3 Diaphragm Bushing	7 Lock Nut
4 Spring Plunger	8 Adjusting Screw

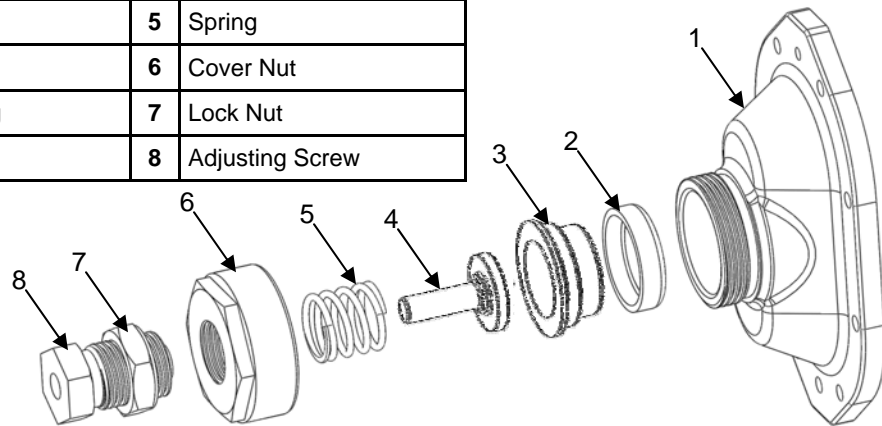

Figure 63: Vented Cover

Jacketed Cover

The jacketed cover option (Figure 64) allows for heating or cooling fluid to be circulated through to match the demands of certain products. This fluid (media) can preheat or cool the fluid end and sustain the product temperature during operation and short shut downs. The jacketed cover is not a heat exchanger and is not designed to primarily control the product temperature. This option requires longer gear case mounting studs. Please contact Q-Pumps for replacement information. The pressure limit for the jacketed cover is 60 psi.

ZP3 Pump Model	Thread Size
6, 15, 18, 30, 34, 40	3/4" NPT
45, 60, 64, 130, 134, 180, 184, 220, 224	1" NPT

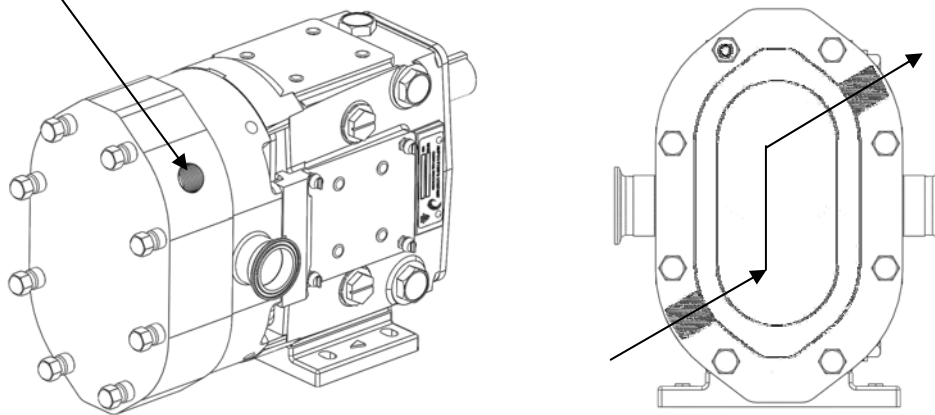

Figure 64: Jacketed Cover

Troubleshooting

Each Q-Pumps ZP3 is assembled and tested at the factory and is designed to have trouble-free operation. Problems may occur over the life of the pump due to system variations, standard wear, or user error. The following table has information that may help identify and solve a problem. For additional technical assistance, please contact with the pump's serial number.

Symptom	Cause	Solution
NO FLOW (rotors are not turning)	Drive motor is not running or connected	Check connection and power source to pump motor drive
	Keys (gear, drive shaft) are sheared or missing	Check or replace
	The pump's drive (gearbox, belts, transmission) is broken or slipping	Check, replace, or adjust
	Pump shafts or gears are broken	Check and replace, if necessary
NO FLOW (rotors are turning)	Rotors are turning in the wrong direction	Check motor connections for correct hookup (see "Pump Rotation" on page 11)
	Discharge port/valve is closed or blocked	Check and open, if necessary
	Inlet port/valve is closed or blocked	Check and open, if necessary
	Pump relief valve (optional) is not set correctly, or is held open by foreign matter.	Check and clean, if necessary. Check system so that unwanted debris doesn't enter pump
NO FLOW (pump is not priming)	Inlet valve closed	Open valve, if necessary
	Inlet line restricted or clogged	Clean lines and check system
	Too much air in the inlet line	Check lines for leaks, replace gaskets or pipes, if needed
	The pump's speed is too low	Increase speed of pump
	The pump's speed is too high	Check viscosity of product, and reduce speed as needed
	No product in the inlet lines (lines drain or siphon when pump is off)	Foot valves or check valves may be used. Having product in the line is necessary for the pump to prime
	Pump is air locked	Install air bleeds to the pump and lines
	Pump may be worn out	Increase the pumps speed or replace worn out rotors.
	Inlet pressures too low	Check pressure required. Change, if necessary
	Differential pressure differences not developing	Install check valves on discharge to prevent large back pressures

Troubleshooting

Symptom	Cause	Solution
Inadequate Flow	Speed is too low or too high	Check published pump curve and adjust speed, if necessary
	Air leaks in inlet line	Check for bad seals, bad gaskets and piping connections.
Inadequate Flow and Flow is Bypassing Pump	Open valve (inlet drain, trap valve)	Check valves and close, if needed
	Relief valve not adjusted correctly or stuck	Check relief valve and adjust, if necessary
Inadequate Flow, Pump is Noisy During Operation (slipping)	Non-standard rotors (Hot clearance, Hot Chocolate clearance, Stainless) are being used on low viscous fluids	Use appropriate rotors for product (contact Q-Pumps for additional support, if needed)
	Body and rotors are worn	Increase speeds, replace rotors, or have the pump remanufactured (Page 36)
	Pressures are too high for pump	Adjust system
Starved Pump Inlet (fluid vaporization)	Strainers, valves (inlet side), fittings, or lines are plugged or restricted	Check and clean lines/valves.
	The Inlet line is too small (inside diameter) or long, or both.	Increase inlet pipe size and/or decrease pipe length
	Too many valves or fittings	Reduce number of fittings or valves
	Valves or strainers are too small	Check and change, if necessary
	The net inlet pressure is too low	Check pump and system requirements and change system or pump, if necessary.
	Product viscosity greater than expected	Change system parameters (temperature, flow, pressure)
	Product temperature is higher than expected	Reduce speed, temperature and flow, if necessary
Excessive Power is Required (pump overheats, stalls, draws high current, fuses/ breakers are tripping)	Viscosity losses higher than expected	Increase pump speed, if needed
	Pressures higher than expected	Decrease pump speeds and modify inlet line sizes
	Viscosity is higher than expected	Heat product, or change system parameters
	Viscous product sits in line during shutdown	Install a soft start on motor drive, clean lines or change system to avoid problem

Troubleshooting

Symptom	Cause	Solution
Noisy Operation (cavitation)	Product's viscosity, vapor pressure and temperature are too high	Check system setup. Change speeds and temperatures, accordingly
	The inlet pressure available is less than required	Check inlet pressure requirements and adjust accordingly
Noisy Operation (air or gas in fluid)	Air leaks in the system	Check for leaks and correct, if needed
	Product emits gases	Install pressure relief valves
Noisy Operation (rotor to body contact)	Assembly without checking fluid end clearances	Check pump clearances and adjust, if necessary (page 22)
	Internal stresses in pump caused by improper piping support	Adjust system to eliminate stresses (page 8)
	Pressures are higher than what the pump is rated for	Reduce pressures
	Bearings are worn	Check for bearing movement (page 14) and replace, if necessary
Noisy Operation (rotor to rotor contact)	Gears are loose or incorrectly timed (damage to rotor may be severe)	Rebuild pump with new parts
	Keys are sheared	Inspect and rebuild, if necessary
	Gears are worn	Inspect and replace gears, if needed. Inspect damage to rotors and rebuild, if necessary
Noisy Operation (external mechanical problems)	Gear drive, drive belts, coupling or bearings are worn or not correctly adjusted	Check and replace. Adjust, if needed
Short Pump Life	Product is abrasive	Check system, and possibly implement a larger pump at lower speeds
	Pump speeds and pressures are higher than pump rating	Check system and change, if necessary. Reduce speeds and pressure of pump
	Improper gear case lubrication	Check and replace worn out gears and bearings; follow procedures on page 12 for proper lubrication
	Water build up in Gear case	Check that all gear case plugs are in place
	Misalignment in system (piping or pump drive)	Check and modify system to eliminate alignment issues

Remanufacturing Program

PD Pump Remanufacturing Program

With the purchase of each new ZP pump, Q-Pumps guarantees two full remanufactures. Depending on wear, the ZP pumps (and equivalents) can be remanufactured up to four times. This process returns a used pump to new pump performance and appearance. Each fully remanufactured pump includes a one year warranty. The following upgrades are included when remanufacturing a competitor's pump: 17-4 shafts, stainless steel bearing retainers, helical gears, and sealed clean out plugs. These upgrades are standard to Q-Pumps positive displacement new and remanufactured pumps.

Contact your local distributor or the factory +52 (442) 1033 100 for more information.

ATEX Certification

ATEX Certification Information

- 1) Q-Pumps DOC (declaration of conformity) must be included with the pump's installation and maintenance manual.
- 2) ATEX certified pumps will be sent with black plugs on all drain and level ports at the rear of the gear case.
- 3) ATEX approval becomes void if non-Q-Pumps replacement parts are used in the pump.

For additional support regarding ATEX certification, please contact the Engineering Department at Q-Pumps , +52 (442) 1033 100.

Terms and Conditions

1. ENTIRE AGREEMENT. This document contains all of the terms and conditions of the agreement (“the agreement”) between Q-Pumps S.A. de C. V. (“Seller”) and the purchaser (“Purchaser”) of the Products (“Products”) to be sold to Purchaser, to the exclusion of any other statements and agreements, and to the exclusion of any terms and conditions incorporated in Purchaser’s order or other documents of Purchaser. Seller’s acceptance of Purchaser’s order is expressly conditioned on Purchaser’s acceptance of the terms and conditions contained herein, and Purchaser, upon placing an order, is presumed to have accepted all the terms and conditions without modification. No alteration, waiver, modification of or addition to the terms and conditions herein shall be binding on Seller unless set forth in writing and specifically agreed to by an officer of Seller. No course of dealing, usage of trade or course of performance will be relevant to supplement or explain any terms used in the agreement. All offers to purchase, quotations and contracts of sale are subject to final acceptance by Seller at its home office at Querétaro, Querétaro.

2. PRICES. Prices for Products manufactured by Seller pursuant to written accepted orders will remain firm for thirty (30) days from the date of any subsequent price change.

3. TERMS OF PAYMENT. Standard terms are ½% 10 days, 30 days net, from date of invoice unless otherwise stated. If, in the judgment of Seller, the financial condition of Purchaser at any time does not justify continuance of production or shipment on the terms of payment specified, Seller may require full or partial payment in advance. In cases of delays in payment, Seller reserves the right to charge interest on delinquent balances at the rate of 1 ½% per month.

4. DELIVERY. Except as otherwise provided expressly stated in the agreement, Products are sold F.O.B. EXW México. Seller will use reasonable commercial efforts to fill orders within the time stated, but the stated delivery date is approximate only, and Seller reserves the right to readjust shipment schedules without liability. Acceptance by Purchaser of the Products waives any claim for loss or damage resulting from a delay, regardless of the cause of the delay. Except as otherwise provided herein, Seller will not be responsible for freight, transportation, insurance, shipping, storage, handling, demurrage or similar charges. Claims by Purchaser for shortages in the Products must be made to Seller in writing within ten (10) days after date of receipt of the Products. No such shortage shall entitle Purchaser to withhold payment for Products which were received by Purchaser. Each such claim shall set forth in detail the basis and amount of such claim.

5. TAXES AND FEES. Seller shall pay all present and future sales, excise, privilege, use or other taxes, customs duties, and all other fees or other costs, imposed by any federal, state, foreign, or local authorities arising from the sale, purchase, transportation, delivery, storage, use or consumption of the Products or will, if applicable, provide Seller with an appropriate exemption certificate. Seller shall be under no obligation to contest the validity of any such taxes or to prosecute any claims for refunds or returns.

6. INSTALLATION. The Products shall be installed by and at the expense of Purchaser.

7. LOSS, DAMAGE OR DELAY. Seller will not be liable for loss, damage or delay resulting from causes beyond its reasonable control, including, without limitation, strikes or labor difficulties, lockouts, acts or omissions of any governmental authority or Seller, insurrection or riot, war, fires, floods, Acts of God, breakdown of essential machinery, accidents, embargoes, cargo or material shortages, delays in transportation, lack of production capacity or inability to obtain labor, materials or parts from usual sources. In the event of any such delay, performance will be postponed by such length of time as may be reasonably necessary to compensate for the delay. In the event performance by Seller under the agreement cannot be accomplished by Seller due to any of the foregoing causes within a reasonable period of time, Seller may, at its option, terminate the agreement without liability.

8. RETURNS. No Products or parts may be returned by Purchaser without the prior written consent of Seller.

9. WARRANTY. Seller warrants that the Products manufactured by Seller will be free from defects, material and workmanship under normal use and service for a period of one (1) year from date of shipment. In addition, the specified rating of each pump is warranted; however, the characteristic shape of the performance curves may vary from the published standards, and the capacity, head and efficiency guarantees are based on actual shop tests using clear cold water, and therefore the rating is specified in equivalent units of clear cold water. The sole obligation of Seller and the exclusive remedy of Purchaser for breach of this warranty shall be the repair (at Seller’s facility) or replacement by Seller (F.O.B. EXW México), at Seller’s option, of any parts found to be defective, without charge and shall be conditioned upon Seller receiving written notice of any alleged breach of this warranty within a reasonable time after discovery of the defects, but in no event later than the end of the warranty period. The parts alleged to be defective shall be returned to Seller upon its request, freight prepaid. This warranty does not cover ordinary wear and tear, abuse, misuse, overloading, alteration or Products or parts which have not been installed, operated or maintained in accordance with Seller’s written instructions. Seller shall not be liable for any expenses for repairs, additions or modifications to the Products outside of Seller’s factory without its prior written consent, and any such repairs without such consent shall void this warranty. THIS WARRANTY IS EXCLUSIVE AND IS IN LIEU OF ALL OTHER EXPRESS AND IMPLIED WARRANTIES WHATSOEVER, INCLUDING BUT NOT LIMITED TO IMPLIED WARRANTIES OF MERCHANTABILITY AND FITNESS FOR A PARTICULAR PURPOSE. Seller may from time to time provide its facilities, personnel and experience to assist customers in the selection of materials, design, installation and operation of Products for maximum resistance to corrosion and abrasion with due consideration to the economy of the installation. This service is provided in an advisory capacity only and the final selection and operation of the Products and ancillary equipment shall be the sole responsibility of Purchaser or any user thereof. Accessories and parts manufactured by third parties are warranted only to the extent of such third party’s warranty. IN NO EVENT SHALL SELLER BE LIABLE UNDER ANY CIRCUMSTANCES FOR ANY INCIDENTAL, CONSEQUENTIAL OR SPECIAL DAMAGES (INCLUDING, WITHOUT LIMITATION, ANY LOST PROFITS OR LABOR COSTS) ARISING FROM THE BREACH OF THIS WARRANTY OR OTHERWISE ARISING FROM OR RELATING TO THE PRODUCTS OR THEIR SALE, USE OR INSTALLATION.

Terms and Conditions

10. CHANGES. Changes in any work to be performed hereunder may be made only upon Purchaser's written instructions and acceptance by Seller in its discretion. Any change in drawings, materials or design of the Products, or to tools, fixtures or other items used to produce the Products, which affects Seller's cost to produce the Products will entitle Seller to adjust the price to take into account any additional costs. If work has been started, Seller shall be properly reimbursed for work already performed; if Products already produced are not accepted by Purchaser, Seller has the right to adjust the price to take into account any additional costs caused by an increase or decrease in quantities or in the time required for performance under the agreement.

11. TERMINATION. After Seller has commenced work, ordered any materials or made any other commitments pursuant to the agreement, it may be terminated only with the prior written agreement of Seller providing for equitable cancellation charges. Such charges shall reimburse Seller for any completed items at the contract price, and for any work-in-process items at the contract price less the cost to complete. Termination on any other basis must be specifically agreed on in writing in advance between Purchaser and Seller.

12. DEFERRED DELIVERIES. Orders or deliveries will be deferred only upon the prior written agreement of Seller in its discretion, and then only upon the following conditions:

(a) The deferral period may not exceed sixty (60) days. At the end of the deferral period, if no release is provided by Purchaser, Seller reserves the right to render an invoice for and ship the completed portion of the order to the destination specified in Purchaser's order, or to store such material at Purchaser's expense at Seller's standard storage charges then in effect.

(b) For the portion of the order that is not completed, if no release is provided by Purchaser at the expiration of the deferral period, Seller reserves the right to render an invoice for any completed items at the contract price, and for any work-in-process items at the contract price less the cost to complete.

(c) Purchaser shall bear the risk of loss or damage to materials held at Purchaser's request.

13. LIMITATION OF LIABILITY. IN NO EVENT SHALL SELLER BE LIABLE UNDER ANY CIRCUMSTANCES: (a) FOR ANY INCIDENTAL, CONSEQUENTIAL OR SPECIAL DAMAGES (INCLUDING, WITHOUT LIMITATION, ANY LOST PROFITS OR LABOR COSTS) ARISING FROM OR RELATING TO THE PRODUCTS OR THEIR SALE, USE OR INSTALLATION; (b) FOR DAMAGES TO PROPERTY (OTHER THAN THE PRODUCTS PURCHASED FROM SELLER); (c) FROM ANY BREACH OF ITS WARRANTY OR ANY OTHER OBLIGATIONS TO BUYER; OR (d) FOR ANY OTHER CAUSE WHATSOEVER, WHETHER BASED ON WARRANTY (EXPRESSED OR IMPLIED) OR OTHERWISE BASED ON CONTRACT, OR ON TORT OR OTHER THEORY OF LIABILITY, AND REGARDLESS OF ANY ADVICE OR REPRESENTATIONS (WHETHER OR NOT IN WRITING) THAT MAY HAVE BEEN RENDERED BY SELLER CONCERNING THE DESIGN, MANUFACTURE, SALE, USE OR INSTALLATION OF THE PRODUCTS.

14. INFRINGEMENT. Seller at its expense will defend and hold Purchaser harmless from and against all damages, costs and expenses arising from any valid claim of infringement by a third party with respect to any patent or other intellectual property rights (collectively, the "Intellectual Property Rights") caused by Products originally manufactured by Seller, provided Purchaser (a) has not modified such Products, (b) gives Seller immediate notice in writing of any claim or commencement or threat of suit, and (c) permits Seller to defend or settle the same, and gives all immediate information, assistance and authority to enable Seller to do so. In the event any such originally manufactured Products are held to infringe an Intellectual Property Right and if Purchaser's use thereof is enjoined, Seller will, at its expense and option: (1) obtain for Purchaser the right to continue using the Products, (2) supply non-infringing Products, (3) modify the Products so that they become non-infringing, or (4) refund the then market value of such Products. In no event shall Seller's liability exceed the sale price of the infringing Products. THE FOREGOING REPRESENTS SELLER'S ENTIRE AND EXCLUSIVE OBLIGATION WITH RESPECT TO ANY CHARGE OF INFRINGEMENT OF ANY INTELLECTUAL PROPERTY RIGHT AND IS IN LIEU OF ANY STATUTORY WARRANTY RELATING TO INFRINGEMENT. Notwithstanding the foregoing, Seller shall have no liability as to any Products or parts thereof that are manufactured or modified by Purchaser or a third party, or that are manufactured or modified by Seller in accordance with Purchaser's specifications. Purchaser will defend and hold Seller harmless from and against all damages, costs and expenses whatsoever arising from any claim for infringement of any Intellectual Property Rights relating to Products that have been manufactured or modified by Seller according to specifications provided by Purchaser.

15. CERTAIN LAWS. Seller will comply with the applicable requirements of the Fair Labor Standards Act of 1938, as amended, Executive Order 11246, and THE rules, regulations and orders of the Secretary of Labor relating thereto.

16. PERIOD FOR ACCEPTING QUOTATIONS. Unless accepted without modification within thirty (30) days of issuance, or prior to withdrawal by Seller if earlier, all quotations automatically expire at the end of such thirty (30) day period.

Terms and Conditions

17. PROVISIONS FOR INTERNATIONAL TRANSACTIONS. The following provisions shall apply if the Products are to be shipped to Purchaser at a location outside México, and apply regardless of other provisions set forth in these Terms and Conditions:

(a) The 1980 United Nations Convention on Contracts for the International Sale of Products shall not apply.

(b) Except as otherwise provided expressly stated in the agreement, terms of delivery are Ex-Works (within the meaning of INCOTERMS 2000) and all customs fees, import duties, cargo insurance, taxes and other charges imposed on or relating to the purchase or sale of the Products shall be paid by Purchaser in addition to the stated price.

(c) Except as otherwise provided expressly stated elsewhere in the agreement, payment shall be made by issuance to Seller of an irrevocable letter of credit which (i) is issued and confirmed by a U.S. bank acceptable to Seller, (ii) is governed by the Uniform Customs and Practice for Documentary Credits (UCP 600) and otherwise acceptable in form and substance to Seller, and (iii) provides for payment to Seller of the purchase price in U.S. dollars upon presentation by Seller of Seller's certification and/or such other documents as shall be required by the letter of credit. All banking and other charges for such letter of credit shall be for the account of Purchaser.

(d) Prices include Seller's standard commercial export packaging which may vary depending on whether shipment is made by air, land or sea. Except as otherwise provided expressly stated in the agreement, Purchaser will bear any additional expenses required to satisfy Purchaser's packaging requirements. Packages will be marked in accordance with Purchaser's instructions, if any. Seller shall furnish packing lists and such other information as may be necessary to enable Purchaser's agent to prepare documents required for export shipment.

(e) All shipments hereunder are subject to compliance with the U.S. Export Administration Act, as amended, regulations thereunder and all other U.S. laws and regulations concerning exports. Purchaser shall comply with all such laws and regulations concerning the use, disposition, re-export and sale of the Products provided hereunder.

18. GENERAL. No modification or waiver of the agreement or any of its provisions is valid unless expressly agreed to by Seller in writing, and no waiver by Seller of any default under the agreement is a waiver of any other or subsequent default. The unenforceability or invalidity of one or more of the provisions of the agreement will not affect the enforceability or validity of any other provision of the agreement. Purchaser may not assign any of its rights, duties or obligations under the agreement without Seller's prior written consent and any attempted assignment without such consent, even if by operation of law, will be void. The agreement is governed by and shall be construed in accordance with the laws of the State of Wisconsin, including the Uniform Commercial Code as enacted by such state, without giving effect to its conflict of laws principles.

Return Policy

This policy is intended for returns that are not covered by product warranty, i.e. wrong pump or part was ordered, customer canceled order, etc. Before returning any product, contact us for a Returned Material Authorization Number (RMA#). This will eliminate confusion when the parts are received and facilitate processing the return. No action will be taken on returned parts without an RMA.

<u>Type of Return</u>	<u>Restocking Charge</u>
Standard pump with a replacement order	10%
Standard pump without a replacement order	15%
Standard parts with a replacement order	5%
Standard parts without a replacement order	10%

Additional restocking charges may be assessed for any of the following circumstances.

1. Special order motors and seals are not returnable unless we have a use for them. Credit will be determined on a case-by-case basis.
2. Impellers that are trimmed to a diameter that we don't regularly use are not returnable. Credit will be determined on a case-by-case basis.
3. Used seals and motors are not returnable.

Credits

Credit will be issued only after parts are returned and inspected. Customer is responsible for packaging parts so they are returned in "as new" condition. Any labor required by Q-Pumps to return the parts to "as new" condition will be deducted from the credit.



Q-Pumps S.A. de C.V.
Acceso "A" #103, Fracc. Ind. Jurica
Querétaro, Qro. México, 76130
Phone: +52 (442) 218 4570 or +52 (442) 103 3100
Fax: +52 (442) 218 4577
Email: sales@qpumps.com