



Operation and Maintenance Manual
of Positive Displacement Pump

QTS series

Twin Screw Pump

QTS-M08.1



www.qpumps.com

support@qpumps.com



About this Manual **3**

 Q-Pumps Warranty 3

 General Information 4

 Damage or Loss During Shipment 4

 Receiving the pump 4

Safety **5**

 Electrical Connections 5

 Temperature 6

 Moving Parts 6

 Lifting the Pump 6

Know your Pump **8**

 Nomenclature 9

 Data Sheet Example 10

 Pump General Assembly 11

 Pump Arrangement Assemblies 11

 QTS Rotors and Clearances 12

 Using Variable Frequency Drives 12

Base Allignment **12**

Pump Operation **14**

 Starting Up Procedure 14

 Shutting Down Procedure 14

 Restarting Procedure 14

Maintenance: Pump Assembly and Disassembly **15**

 Tools and Spare Parts 15

 Oil and Oil Change 15

 Exploded View 16

 Bill of Materials 19

 Torque Values 19

 Pump Disassembly 20

 Removing the Rotors 20

 Mechanical Seals Replacement 22

 Uninstalling the Single Mechanical Seals 23

 Installing the Single Mechanical Seals 24

 Uninstalling the Double Mechanical Seals 26

 Installing the Double Mechanical Seals 28

 Rotor Assembly 32

 Rotor Synchronization 34

 Bearing Replacement 38

 Important Notes 46

Risks to Consider **48**

Troubleshooting **49**

Annex A: CIP **50**

Annex B: Nut-and-Locknut Technique **52**

ABOUT THIS MANUAL

To ensure the best performance of your pump, please read this manual before starting it. You will find useful information and instructions for the assembly and disassembly procedures required for the necessary pump maintenance.

For any questions related to the operation, maintenance or installation, please contact your local distributor or directly to Q-Pumps:

Q-Pumps S.A. de C.V.
Acceso "A" #103, Fracc. Industrial Jurica
Querétaro, Gro., México, 76130
Call: +52 (442) 218 1600
Fax: +52 (442) 218 4577
E-mail: support@qpumps.com
Web: www.qpumps.com

The information in this manual might change without notice, we recommend to visit our website for any updates.

Q-Pumps S.A. de C.V. Warranty

Q-Pumps guarantees that all manufactured and sold products are free from defects in materials and manufacture for a period of one (1) year from the date of shipment. The warranty does not apply to products which require repair or replacement due to what is considered normal wear. Conditions caused by normal wear include (but are not limited to standard rotors wear) casing, mechanical seals, gears and bearings wear.

Accidents, operating errors or improper maintenance are not covered by the warranty. Q-Pumps assumes no liability for incidental, accidental or consequential damages. The purchaser by acceptance of delivery assumes all liability for the consequences of use or misuse by it, its employees or third parties. Unless they are approved in advance, Q-Pumps does not assume any costs related to parts and / or service.

Q-Pumps disclaims any responsibility for modifications or conversions to the pump and the system. For security reasons and functionality use original parts only. The use of other parts voids the warranty and excludes liability for any consequences.

The pump is designed only for pumping fluids under established characteristics in the selection sheet. Any other use besides the intended one without the prior written consent of the manufacturer's application, will result in disclaim of any responsibility from Q-Pumps.

If the pump is stored temporarily or indefinitely, avoid weather exposure and protect the connection ports with plastic plugs supplied with your pump. Turn the pump shaft by hand every two months to change the rotating position of the bearings.

General Information

Every QTS pump is completely assembled, lubricated, synchronized, factory tested and ready to use. Standard maintenance practices are described in this manual. For more information, please see the Maintenance section. Following these guidelines will grant a longer pump service life under a proper usage and installation.

If necessary to return the equipment under warranty, or for some other reason, contact Q-Pumps to receive a Return Material Authorization (RMA).

Damage or loss during shipment

If you receive the equipment in poor condition or it is lost during transportation, file a claim with the carrier immediately. The transport service provider is responsible for collecting the goods, Q-Pumps ensure they received them in perfect conditions.

Receiving the pump

The pump inlet and outlet ports are covered prior to shipment to ensure that no foreign materials enter inside the pump during shipping. If the protective covers are missing at delivery, remove the pump cover and inspect the interior to ensure that it is free of contaminants before energizing the pump. Please keep nearby the pump serial number; this will allow you to order replacement parts and / or make warranty claims. For more information related to shipping damage and warranty claims please see the General Information or Warranty section in this manual.

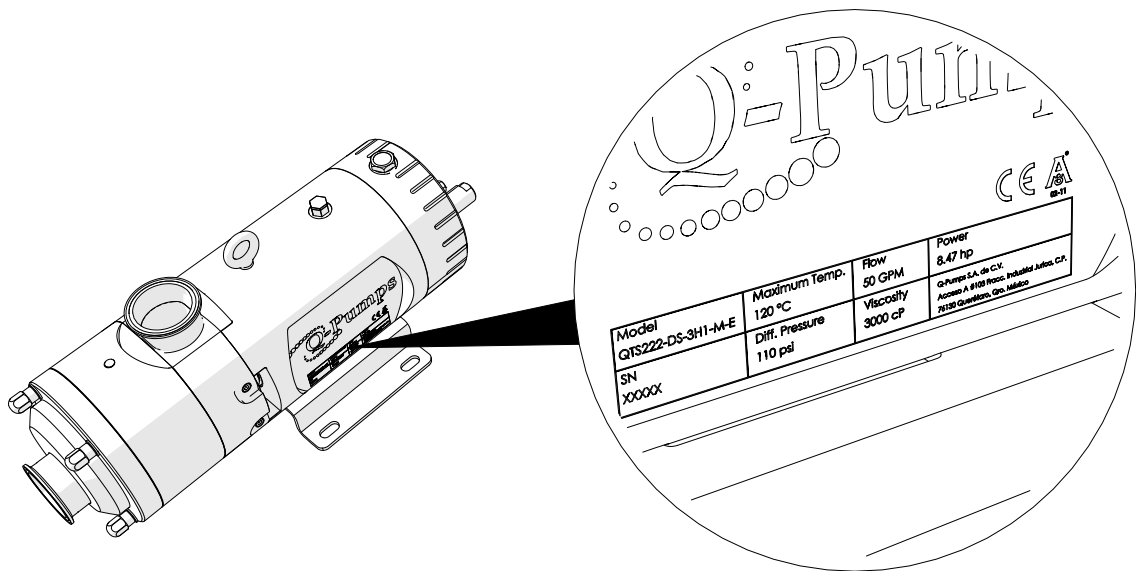

SAFETY

IMPORTANT: Read and understand this manual before installation, operation or maintenance of the pump. Installation, operation and maintenance in combination with inappropriate unsafe practices can cause serious individual risks or death, damage to the environment and the pump itself. Equipment damage caused by user negligence will void the pump warranty.

There are safety symbols used in this manual to identify security situations and how to avoid them:



CAUTION: Hazardous or unsafe practices that may result in minor injuries or damage to equipment or property.



DANGER: A situation in which there is a possibility of a potentially harmful incident; hazardous or unsafe practices that could result in serious injury or death.



ELECTRICAL HAZARD: Risk caused by direct electrical energy contact. Burns, electrical shocks, electric arc and fire or explosions caused directly by electricity.



ROTATING PARTS: Risks from exposure of personnel to rotating parts that may be dangerous and cause injuries. Contact with these parts when carried out without employing security practices such as signs, guards, approach alarms, etc.



TEMPERATURE: The main risk is associated with direct contact of hot or cold sources.

Operate the pump only in accordance with its specific use mentioned in the data sheet and considering the risk and safety issues described in this manual.

In case of malfunction, the pump must be switched off immediately and the responsible staff must attend those malfunctions. Do not allow access to the pump to unqualified personnel. Please contact your distributor.

Avoid operating procedures that endanger the personnel and/or people who are not directly involved in the process. The user must ensure that authorized and qualified personnel carry out the relevant activities of maintenance procedures, operation and installation.

Provide safety devices for any of the following cases and ensure their proper performance:

- If conditions of heat, cold and moving parts are presented in place, provide protection against accidental contact with the pump. Protection must not be removed during the operation. Guards are recommended.
- To avoid electric shocks, ground all electrical systems properly.
- Provide adequate pressure relief devices to prevent excessive pressure on the discharge side of the pump between the pump and the first stop device.
- Always follow local safety guidelines.



Electrical Connections

- A qualified and trained electrician should make the electrical connection to the motor.
- Use safety equipment necessary to manipulate electricity.
- Use appropriate signs in areas where electrical equipment is exposed.
- The pump must be de-energized and secured to prevent startup before starting any work of electrical equipment.
- Use the right wire number according to the motor voltage and amperage.
- Follow diagram connections shown on the motor nameplate; check the motor installation manual for any questions.
- Isolate and protect the terminal ports and connections.
- Make sure the rotation of the pump is correct.
- The motor of your pump has been tested and was selected to meet the requirements of a specific application. The motor amperage consumption should be within the range indicated on the motor nameplate for a proper operation.
- The user is responsible for the safety and proper operation of equipment when special and others motors are used (not supplied by Q-Pumps).



Temperature

The QTS Series are designed to work in a normal temperature range between $-40\text{ }^{\circ}\text{C}$ ($-40\text{ }^{\circ}\text{F}$) and $100\text{ }^{\circ}\text{C}$ ($212\text{ }^{\circ}\text{F}$). Be careful when touching the body and bearing housing to avoid burns when the temperature rises. If the application requires a higher temperature range please contact Q-Pumps to be advised about this case.



Moving Parts

The principle of operation of the QTS Series is by the turning of a pair of synchronized rotors which can trap any foreign object and get stuck due to an improper equipment operation. Never operate the pump without assuring that the front cover is properly in place.

The bearing housing contains rotating parts; never operate the pump without the gear case. Watch precautions with free turning shafts of drive elements when not properly coupled to the pump. Likewise, do not operate the pump without the coupling guard placed in position.



Handling the Pump

Carefully transport the equipment avoiding contact, drops or damage. To prevent any of these situations the QTS Series are provided with an eye bolt located on the bearing housing for lifting.

In the same way, gear motors and motors have an eye bolt (or at least one hole for using this part) located in the body.

Use proper equipment such as elevators or cranes together with slings or straps with the right capacity to lift the total weight.

Take precautions and follow the manufacturer recommendations to use the slings or straps.

When lifting assemblies motor/gear-motor coupled to the pump, always try to lift them up simultaneously. Make sure to place the pump assembly on a stable surface. Once the assembly is positioned in place, check that the assembly is aligned; follow the coupling alignment section in this manual for this purpose.

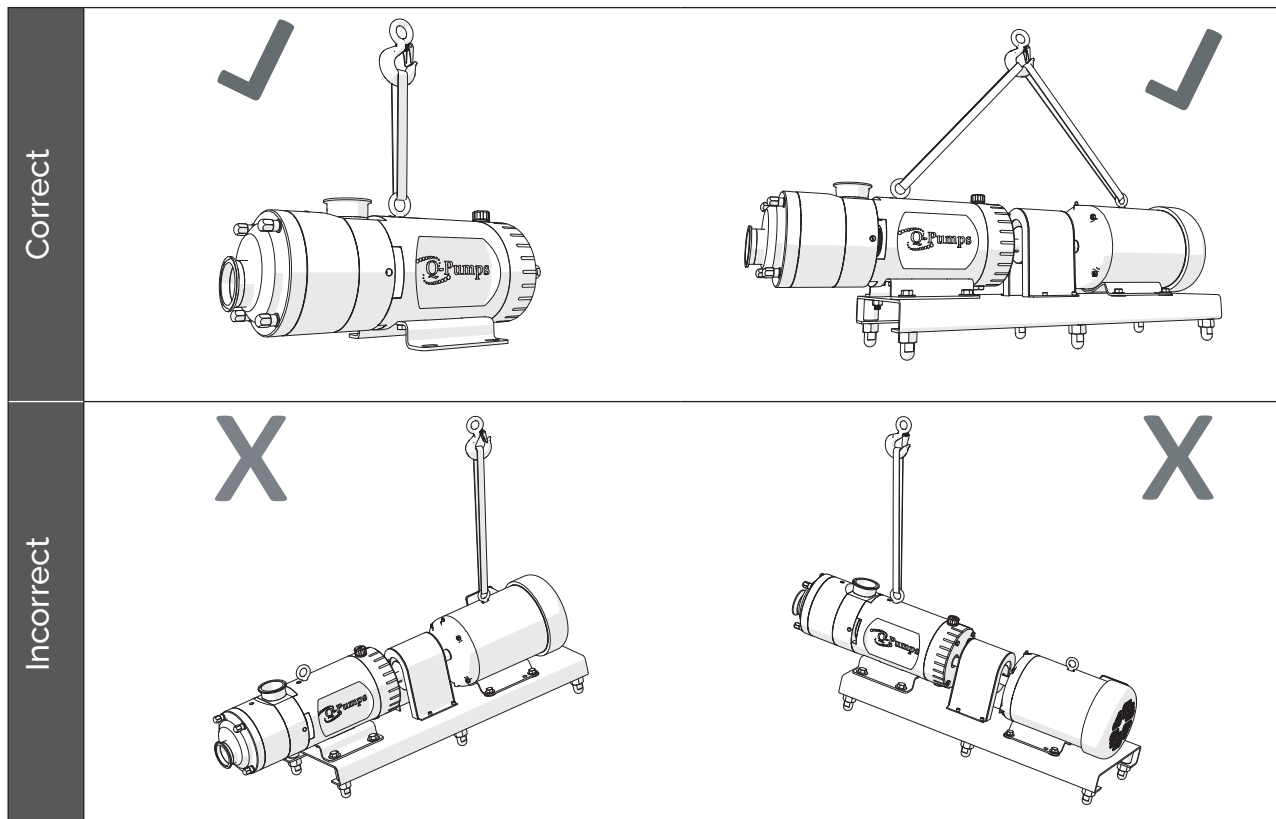

KNOW YOUR PUMP

Congratulations! You've acquired a high technology and quality equipment for your sanitary pumping needs. QTS Series is the best solution toward other brands in the market due to its special characteristics:

- Ideal to pump low and high viscosity fluids (up to 1,000,000 cP).
- All wet parts in contact with the fluid are made of 316L stainless steel.
- Ideal for handling abrasive products.
- Can speed up to 3,000 rpm depending on the pump model, type of fluid and application. It is a bidirectional pump, so it can help recovering line product.
- Can be used as process pumps as well as a CIP pump reducing cost in additional equipment and timing.
- Suction and discharge enlarged option available.
- Totally drainable.
- Even when running at high speed, there is no rotor/rotor/body contact.
- Meets 3A and EHEDG (European Hygienic Engineering and Design) standards.
- Low NPSH requirement thanks to its high suction capacity.
- Can pump fluids with up to 60% entrained air.

Nomenclature and Data Sheet

All QTS pumps have a model number which can be understood by the use of a nomenclature. The model number includes ports size, seals, and rotor type. It can be found printed on top of the pump bearing case and in the selection report. The selection report describes the pump operating conditions for a specific application. Operating the pump in conditions different than selected can void the warranty. If the application changes please contact a distributor or Q-Pumps before operation.



Data Sheet Example

	QTS SERIES 300				Selection No.:		XXXX-01	
	QTS-333-SS-21-M-V				Selected by:		ABC	
					Revision:		A	
Customer								
EXAMPLE								
Date:	7/20/2017	Quantity:	1					
Application Data								
Pumping Fluid:	Concentrate							
Operating Points:	OP 1	OP 2	OP 3	CIP				
Flow (gpm):	50			100				
Viscosity (cSt):	1000			1				
Specific Gravity:	1.1			1				
Suction Pressure (psi):								
Discharge Pressure (psi):	60			15				
Temperature (°C):	4			80				
Particle Size (mm):								
Solids Content (%):								
pH:								
Operating Data								
Shaft Power (hp):	3.64			3.7				
Torque (lb in):	501.74			208.29				
NPSH required *(psia):	1.83			0.12				
Pump Speed (rpm):	457			1120				
Drive Frequency (Hz):	23			56				
Drive System and Mounting								
Type:	6 Pole Motor							
Power (hp):	10							
Torque (lb in):	540							
Speed (rpm):	1200							
Voltage (V):	220/440							
Service Factor:	1.15							
Coupling:	FLEX 7 S EPDM							
Base Size:								
Extras:								
Materials								
			Hardening					
Rotors:	SS 316 L	No						
Pump Casing:		Yes		Chromium Coating				
Frontal Cover:								
Back Cover:								
Shafts:	17-4 PH							
Bearings Housing:								
Guards:	SS 304							
Base:								
Seal								
Type:	Single Mechanical Seal							
Material:	SiC/SiC							
Elastomers:	FKM							
Ports								
		Size		Type				
Front		3 in		Tri Clamp	Suction			
Top		3 in			Discharge			
Pump Ratings								
Maximum Particle Size (in):					1.00 in			
Maximum Differential Pressure (psi):					150			
Threads per Rotor:					2			
Operating Data Curves at Constant Speed								
Variable Pressure Constant Speed Curves								
Notes								
Page:								1

KNOW YOUR PUMP

Pump General Assembly

The pump uses twin screw rotors, when rotating they move the fluid through the casing. The elements inside the gear case are responsible for transmitting the synchronized movement and the force required for pumping the fluid. Bearings, spacers, and shafts are inside the bearing housing.

1. Front cover (with port connection, usually inlet)
4. Pump casing
5. Back cover (with port connection, usually outlet)
6. Bearing housing
7. Pump base plate (NEMA/IEC)
9. Drive shaft
10. Gear case

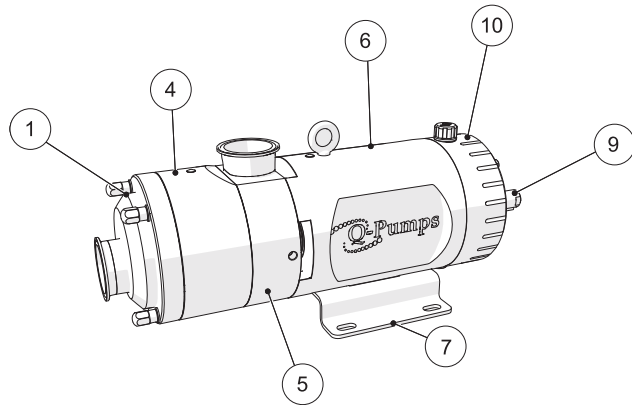

Pump Arrangements / Assemblies

The QTS series pumps can be delivered coupled to a drive element in different ways to solve one specific application. They can be ordered and delivered as follows:

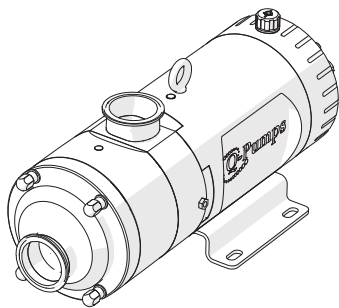

Pump Only

In this case the pump is supplied with a drive shaft for coupling, does not include motor/gear-motor, coupling or base.

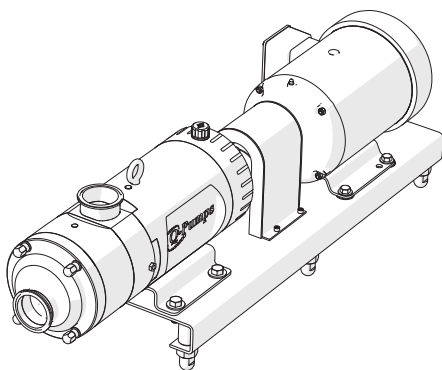

Pump Coupled to a Motor Assembled on a Base

This assembly includes a motor with a coupling, coupling guard and base.

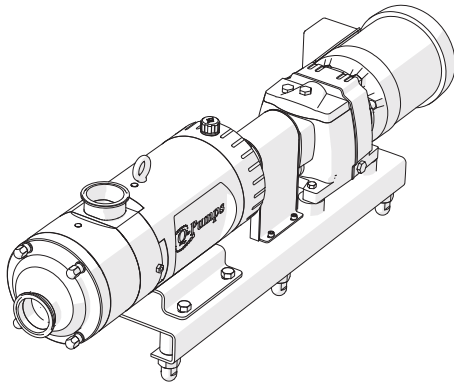

Pump Coupled to a Gear-Motor Assembled on a Base

This assembly includes a gear-motor with a coupling, coupling guard and base.

QTS Rotors and Clearances

The design of QTS rotors (twin screws) in addition to the clearances kept with the casing, allow pumping high viscosity fluids without the risk of contact between them. The correct operation of the pump depends on its proper rotor synchronization.

Using Variable Frequency Drives

Variable frequency drives are useful to perform multiple operating points including the CIP process using the same pump. By changing the speed of the motor the pump can increase or decrease the flow to reach different points of operation. If your equipment is supplied with a variable frequency drive, it's the result of an analysis of the applications of the pump, please follow the data shown in the Data Sheet.

If you want to use a variable frequency drive after the analysis of the application of the pump, please contact your distributor or directly to Q-Pumps to be advised about this case. Remember that using your pump under different conditions than those explained in the Data Sheet may result in damage to the equipment, personnel and it can void your warranty

BASE ALIGNMENT

Pump / base assemblies are aligned in Q-Pumps factory prior to shipment. However assemblies must be checked prior operation to avoid any misalignment. Misalignment may cause unnecessary wear and shorten the life of the pump. You can notice misalignment with excess noise and vibrations. To check and align the pump to its drive first remove the coupling guard.

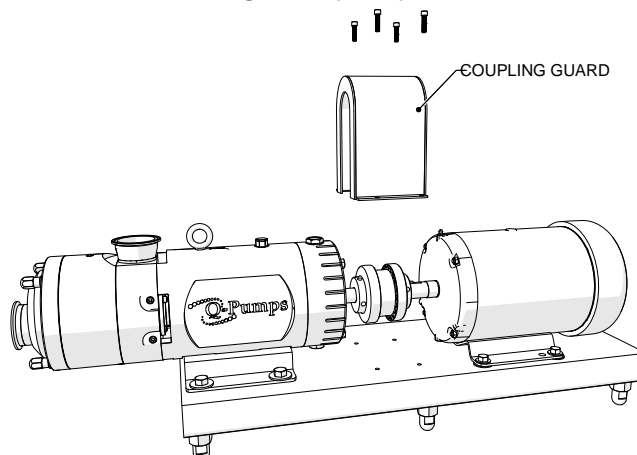

Proceed to verify the angular alignment by measuring the space between the couplings in both vertical and horizontal direction. The measured space has to be equal at both sides of the coupling use shims in the pump base or motor base if needed. Proceed to align the pump and drive parallel to the axis of rotation. Use a straight edge in both top and side of the couplings to guarantee parallelism.

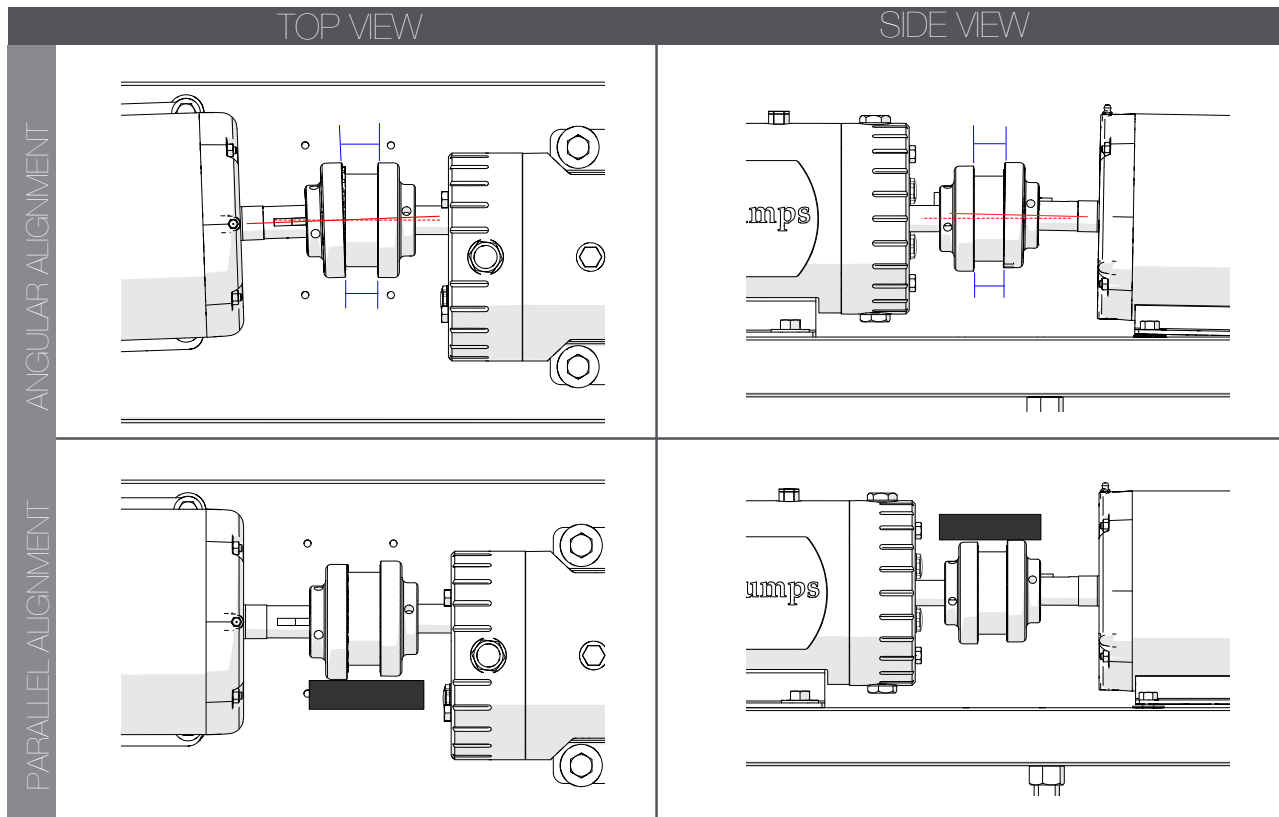

Pump Rotation

Check the direction of rotation prior to connecting the pump to the drive.

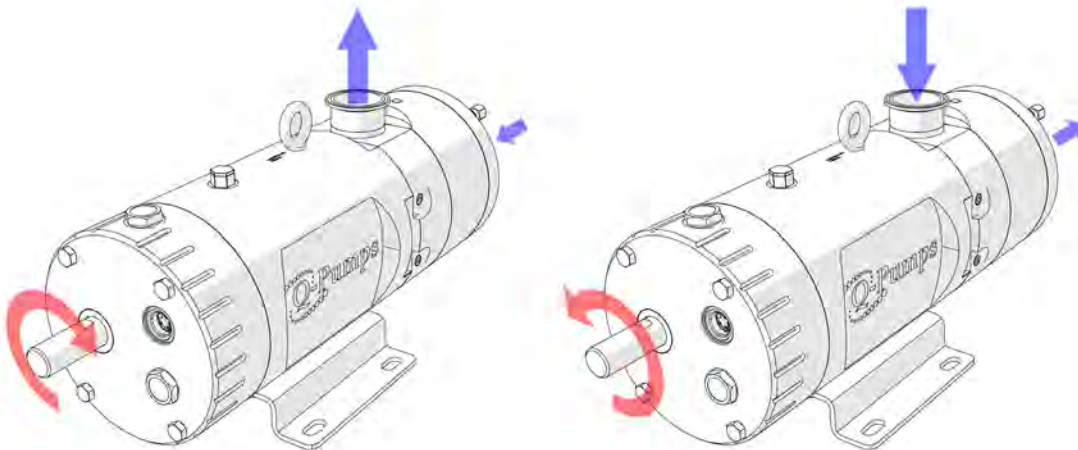

PUMP OPERATION

Follow these steps for the proper operation of your pump before, during and after starting it up. Remember that the correct operation of the pump ensures proper performance and long service life. Not following these recommendations could result in damage to the pump voiding the warranty.

Starting Up Procedure

Before starting the equipment, ensure the following:

- Oil is on its level; otherwise fill the gear case until the oil fills the sight glass.
- Mechanical seals are not leaking. Double mechanical seals must be lubricated without exception. The pump is able to run dry for a short period of time (not recommended). Prevent dry starts to avoid damaging the mechanical seals.
- Jackets are properly connected and have adequate supply of heating or cooling medium.
- The pump is cleaned and sterilized.
- The pump is primed with the fluid to be pumped.
- In order to prevent cavitation, check the valves in the suction side are fully open.
- The valves on the discharge side are fully open to prevent overpressure inside the pump.
- Security measures are taken at the discharge side of the pump to protect against overpressure (open valves, corresponding jacketed piping, by-pass, and recirculation or pressure relief valves).
- The manometers at the discharge are operational.

When starting the motor, check and adjust the operating speed according to the data sheet, after the motor reaches the operation speed search for leaks.

Shutting Down Procedure

After shutting down the motor check the following:

- The pump slows softly. If a variable frequency drive is used both acceleration and deceleration ramps can be programmed.
- If the pump has double mechanical seal even when the pump is stopped keep the supply of the buffer fluid until it is depressurized.
- If a jacket is used please adjust it until the pump temperature goes below a 100 °C/212 °F.

Restarting Procedure

Before restarting the pump check the smooth rotation of the shafts without restrictions and repeat the starting up procedure.

Double Mechanical Seal Lubrication

This diagram is only a reference. there are other ways to connect the lubrication system but always use the lower port as inlet and the top port as outlet. each mechanical seal is independent, the buffer pressure must be less than the process fluid pressure and the maximum buffer pressure is 80 psi (5.5 bar)

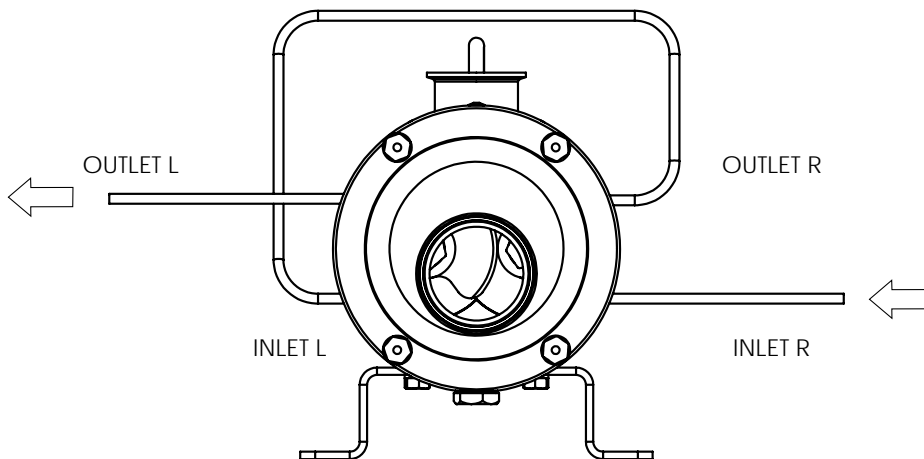

The outlet of the right mechanical seal can be used as the inlet of the left mechanical

Connections Sizes

SIZE	A	Hose OD
QTS 025	M6X1.0	6 mm
QTS 100	1/8 NPT-27	1/4 in
QTS 200		
QTS 300		
QTS 350	1/4 NPT-18	3/8 in
QTS 400		

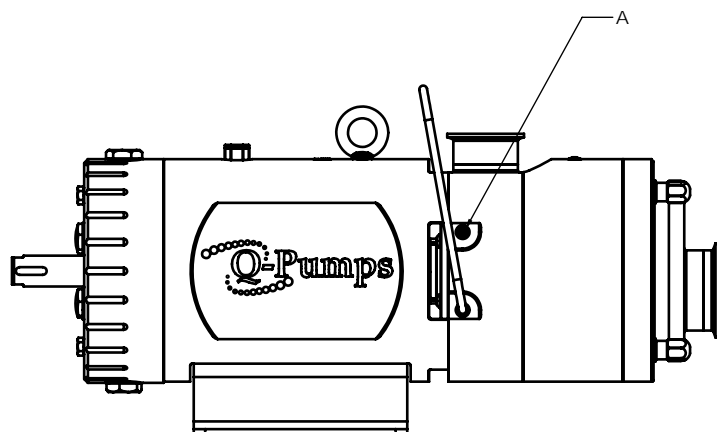

MAINTENANCE: Pump Assembly and Disassembly

To assemble and disassemble the pump, follow the recommendations described below. Always use original spare parts and follow the instructions in this manual. Not following these recommendations could result in damage to the equipment and void the warranty. Remember to read the safety recommendations.

Tools and Spare Parts

Some spare parts such as mechanical seals, O-rings and gaskets kits may be required for solving any contingency.

The following tools are provided with the pump:

1. Special wrench to tighten lock nut (gear case).
2. Hook for O-rings removal.
3. Steel thickness gages in sizes of 0.001, 0.002, 0.004 and 0.008".

You may require these tools:

1. Set of ball end hexagonal L-keys in standard sizes: 3/16", 1/4", 5/16" and 3/8".
2. Socket wrench and set of six points hexagonal sockets.
3. Wrenches 7/8", 1", 1 1/2", 1 1/4", (1 7/8" & 1 15/16 for QTS 400)
4. It is very important to have a torque wrench (capacity from 4 to 50 lb-in).

Also you may need FDA silicone base grease for incidental contact.

Oil and Oil Change

The pump comes with Food Grade Mineral Oil from factory.

Oil Viscosity

Model	Viscosity	Quantity
QTS025	ISO VG -68	55 mL (1.85 oz)
QTS100	ISO VG -68	0.39 L (13.2 oz)
QTS200	ISO VG -68	0.75 L (25.4 oz)
QTS300	ISO VG -68	2.3 L (0.60 gal)
QTS350	ISO VG -100	3.3 L (0.87 gal)
QTS400	ISO VG -100	4.2 L (1.10 gal)

Oil change is needed if one of the following conditions is present:

- First oil change 240 hours
- Non-continuous operation* 2000 hours
- Continuous operation** 2500 hours or 4 months (whichever comes first)

* Twelve or more pump startups per day

** Less than twelve pump startups per day

Exploded View QTS 025

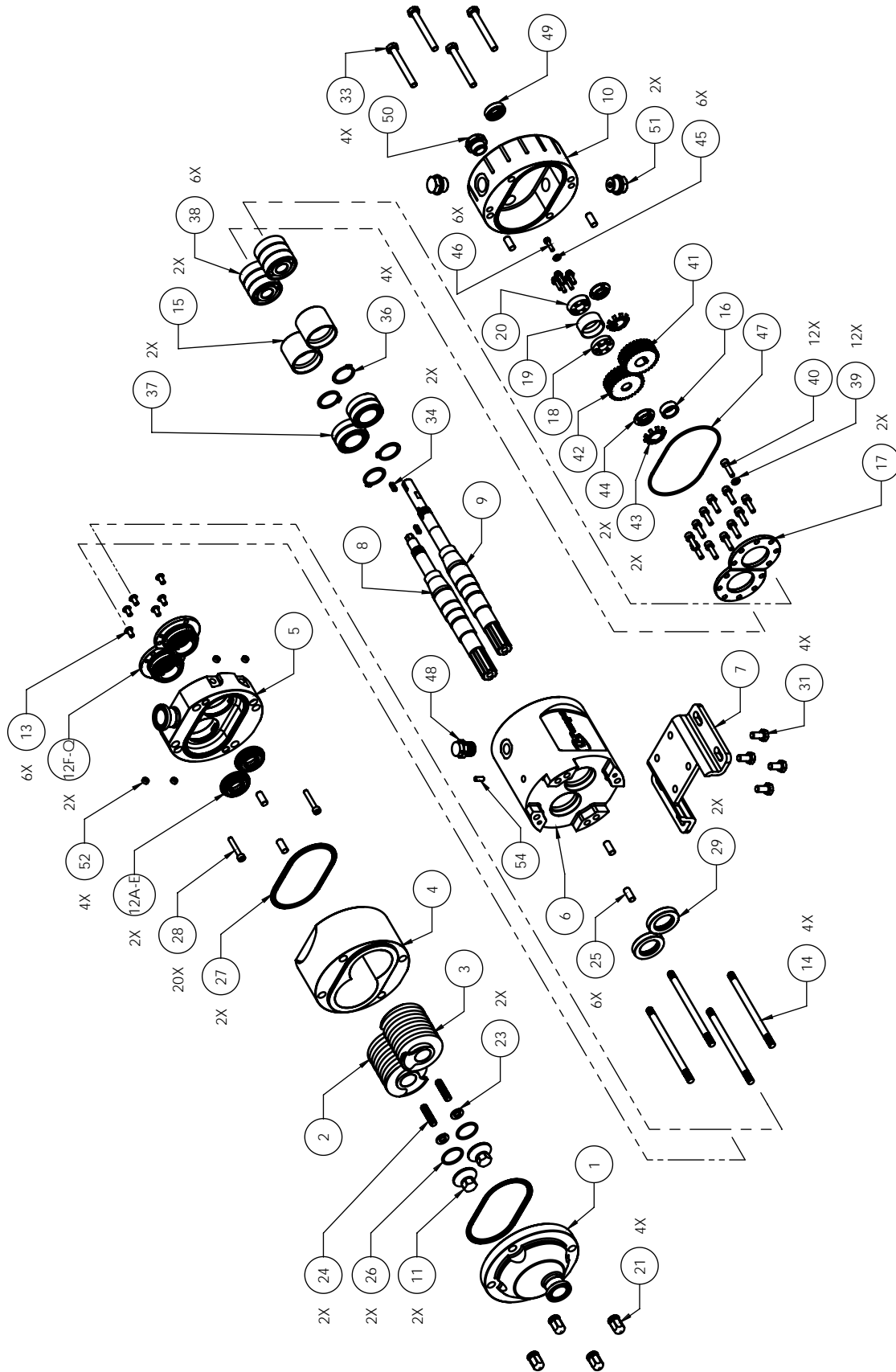

Exploded View QTS 100

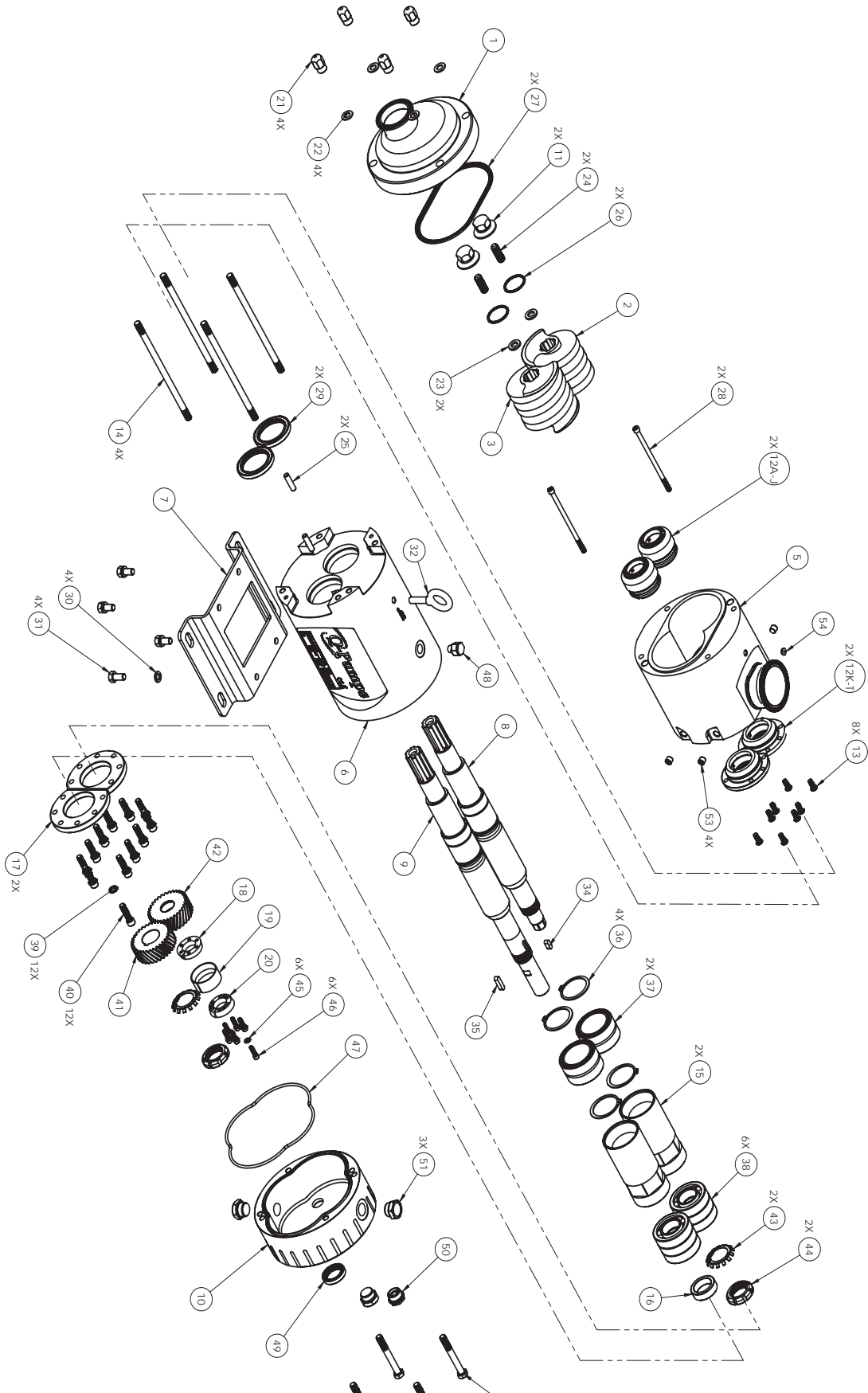

Exploded View QTS 200, 300

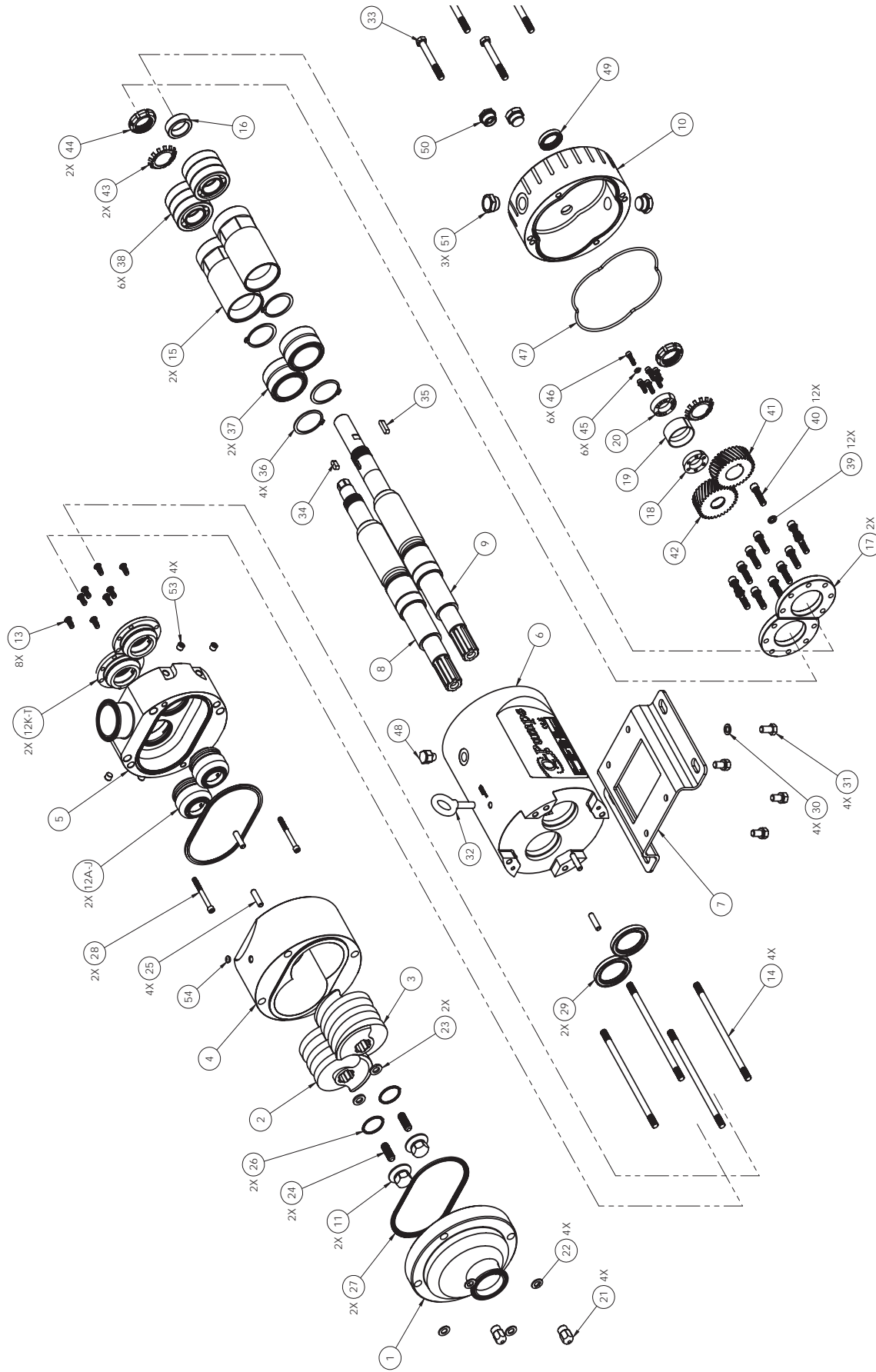

Exploded View QTS 350 y 400

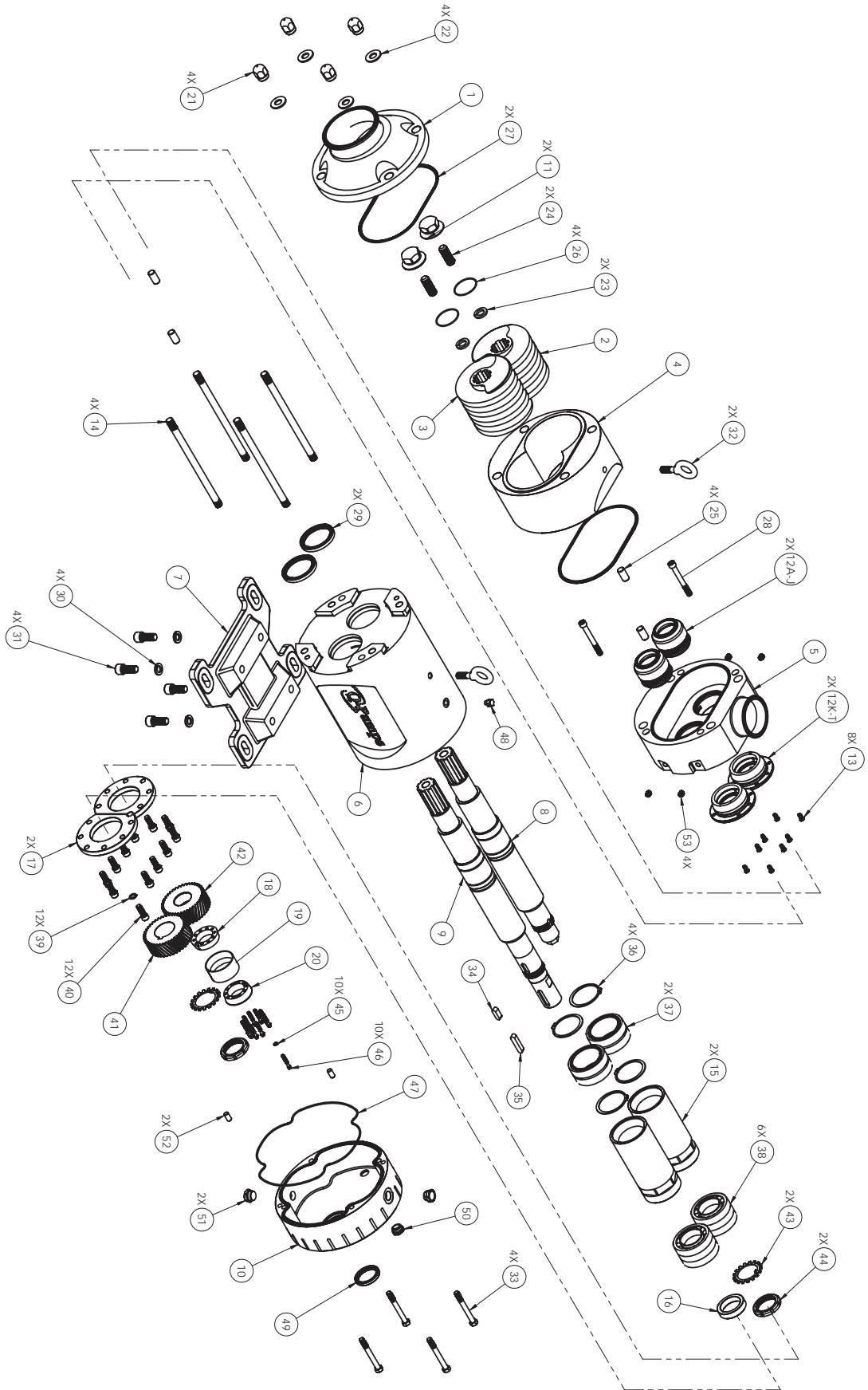

Exploder View QTS HM4 (Rectangular Inlet)

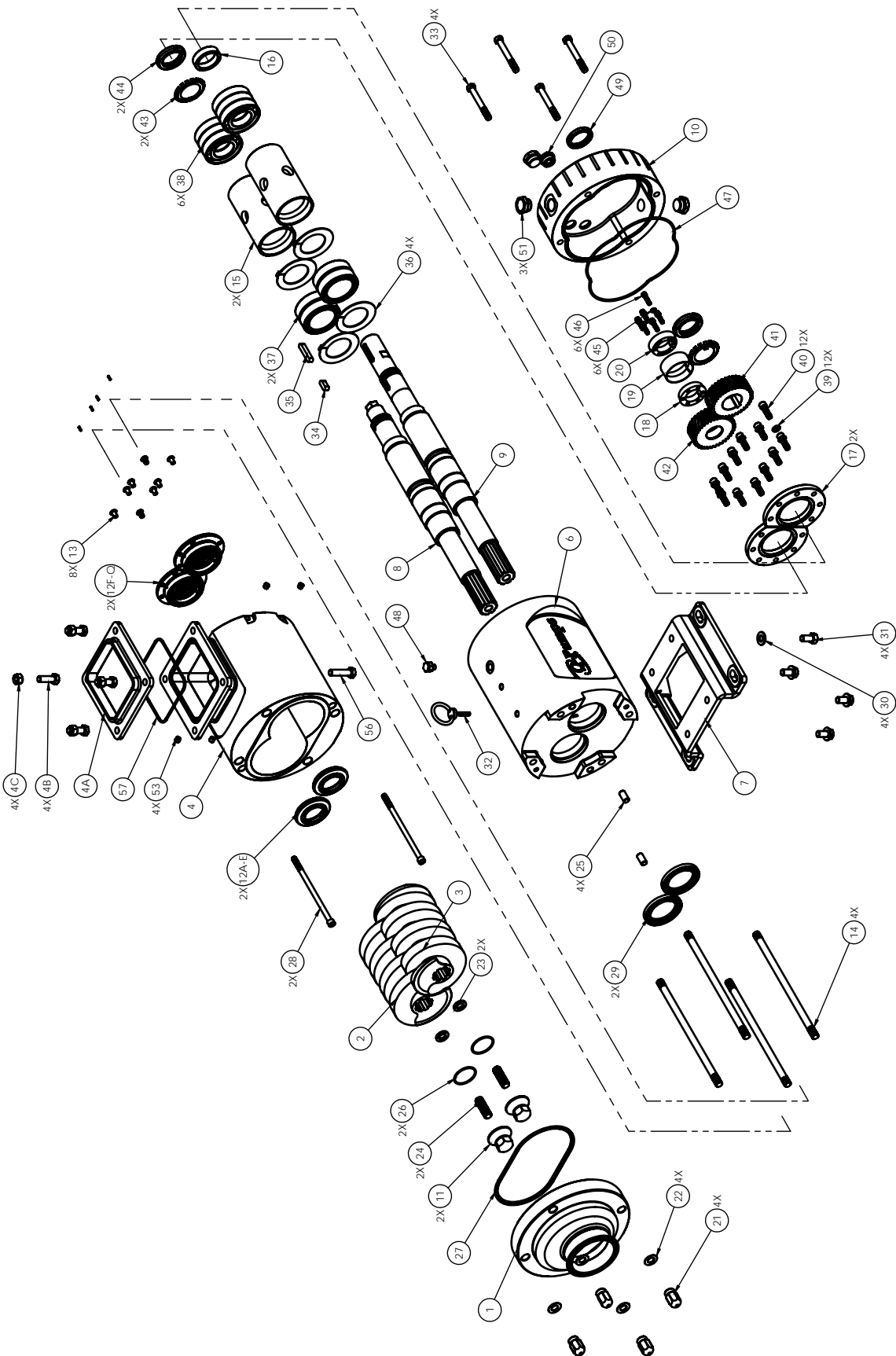



Bill of Materials

Please use this table and diagram to identify every component to be assembled.

Bill of Materials:					
1	Front cover	19	Synchronization ring	37	Front bearing
2	Left rotor	20	Tapered driven ring	38	Rear bearing
3	Right rotor	21	Cover nut	39	Lock washer
4	Pump casing	22	Flat washer	40	Socket head cap screw
5	Back cover	23	Spring washer	41	Drive gear
6	Bearing housing	24	Set screw	42	Driven gear
7	Pump base plate	25	Dowel pin	43	Bearing lock washer
8	Driven shaft	26	O-ring	44	Bearing lock nut
9	Drive shaft	27	Gasket	45	Lock washer
10	Gear case	28	Socket head cap screw	46	Socket head cap screw
11	Rotor nut	29	Front oil seal	47	O-ring
12	Mechanical seal	30	Flat washer	48	Pressure release valve
13	Button/socket head set screw	31	Hexagon bolt	49	Rear oil seal
14	Stud	32	Eye bolt	50	Oil sight glass
15	Bearing spacer	33	Hexagonal bolt	51	Hex Plug
16	Gear spacer	34	Gear key	52	Dowel pin
17	Retaining flange	35	Coupling key	53	Flush nipple
18	Tapered drive ring	36	Lock ring	54	Platic Plug

Note: Depending on the model, some components may not be included.

Torque Values

Use the following torque table to tighten each item when indicated on the manual:

# Part	Piece	QTS 025 lb ft (Nm)	QTS 100 lb ft (Nm)	QTS 200 lb ft (Nm)	QTS 300 lb ft (Nm)	QTS 350 lb ft (Nm)	QTS 400 lb ft (Nm)
21	Front cover nuts	2 (2.7)	15 (13.5)	20 (27)	30 (40.5)	50 (67.5)	50 (67.5)
11	Rotor nut	5 (6.8)	25 (34)	40 (54)	50 (67.5)	60 (81)	70 (94.5)
40	Socket head cap screw (bearings)	2.5 (3.4)	10 (13.5)	15 (20.5)	20 (27)	25 (33.5)	30 (40.5)
44	Bearing lock nut	5 (6.8)	20 (27)	30 (40.5)	40 (54)	50 (67.5)	60 (81)
46	Socket head cap screw (sync ring)	1 (1.35)	1.7 (2.3)	4.2 (5.7)	6.25 (8.4)	6.9 (9.3)	7.5 (10)

Coupling set screws 10 lb-ft for all models.

Hexagonal bolts/hexagonal nuts motor/base, pump/base, 40 lb-ft

Minimum Thickness Gage Between Rotor Flanks

Model	Value in (mm)
QTS 025	0.003 (0.075)
QTS 100	0.006 (0.150)
QTS 200	0.007 (0.175)
QTS 300	0.010 (0.250)
QTS 350	0.010 (0.250)
QTS 400	0.015 (0.380)

NOTE: Value at both flanks of the rotors

Pump Dissassembly



Be sure to read and understand the **Safety section** of this manual before servicing your pump.



De-energize the unit and lock out the mechanism.



Handle all wet parts with caution; prevent harsh contact or scratches and always place them on a clean surface to avoid damage.

The preventive maintenance procedures and inspection comprises the change of the mechanical seals, O-rings and gaskets replacement, oil change, checking the alignment of the coupling as well as noise and vibration issues.

Removing the Rotors

1. Remove the cover nuts (**21**) and flat washers (**22**), use a wrench or a six points socket. Remove the front cover (**1**).
2. Take off carefully the front cover gasket (27), you may use the O-rings hook.
3. Remove the pump housing (**4**) carefully. It is fixed and centered to the back cover (**5**) guided by dowel pins (**25**). Just pull out to slide the housing through the studs (**14**). The pins might come out along with the housing or stay in the back cover. You can also remove the studs to increase the working area. The plug (**53**) is just for sealing a hole on the housing which can be used to lift the casing on larger models.

NOTE: To remove the studs you may use the nut-and-locknut technique (see annex B).

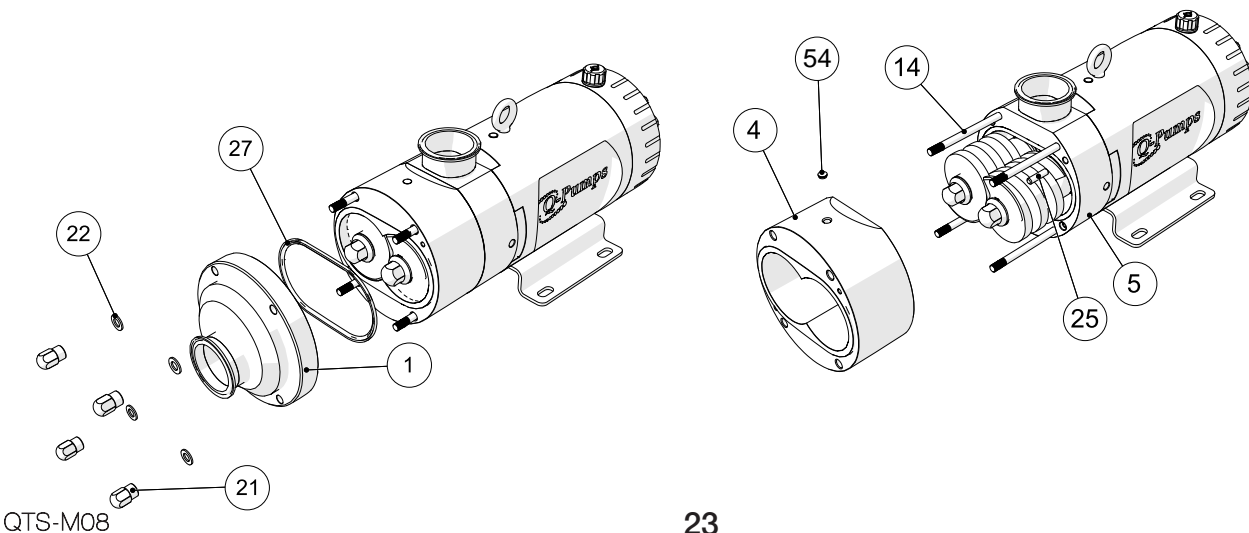

4. Block the rotors with the aid of a wrench using the drive shaft (9) end. Using a six points female socket loosen the rotor nuts (11). First loosen the left side rotor (2) nut torque, then change to the right side rotor (3) and just loosen the torque of the second nut. Slowly loosen simultaneously the two rotor nuts until both are out.
5. The objective is to loosen both nuts simultaneously to avoid contact between rotors.

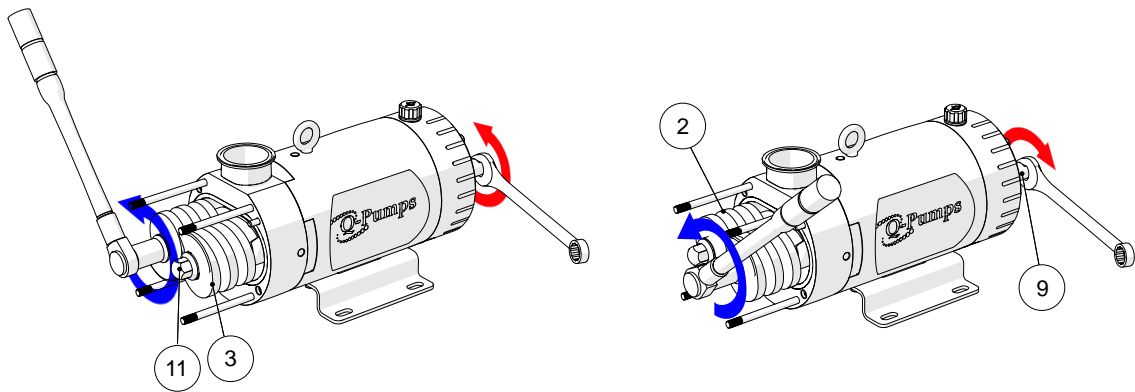

6. Remove the O-rings (26), spring washers (23) and the rotor nut socket set screws (24).
7. Take off the gasket (27) placed on the back cover. Sometimes this gasket may get stuck to the casing, pull out carefully to avoid damaging it with the studs or rotors. Pull straight out both rotors along the shafts.

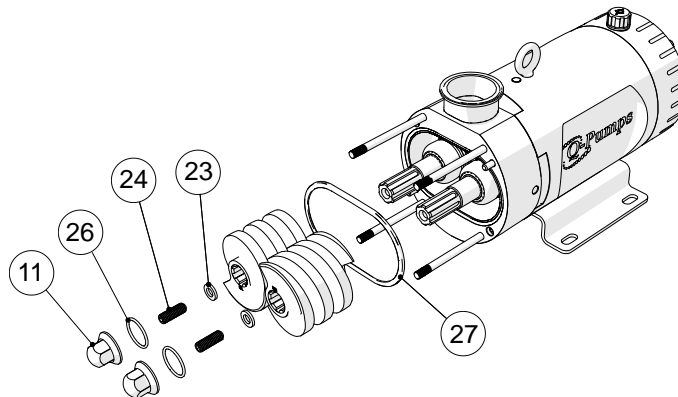

8. You have finished the removal of the rotors procedure. Every time you replace the rotors with new ones, be sure to perform the synchronization procedure. Now continue with the replacement of the mechanical seals.

Mechanical Seals Replacement

Here is a description of the procedures for inspection and replacement of the mechanical seals. Every pump has a pair of mechanical seals.

SINGLE MECHANICAL SEAL

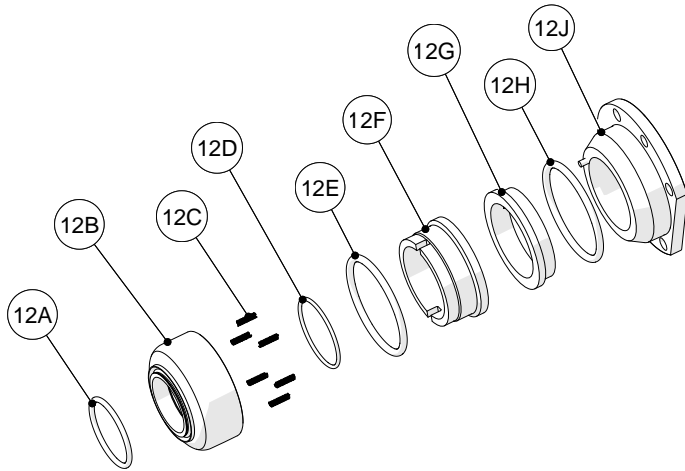

Notes: QTS 100 and QTS rectangular Inlet uses a wave spring

DOUBLE MECHANICAL SEAL

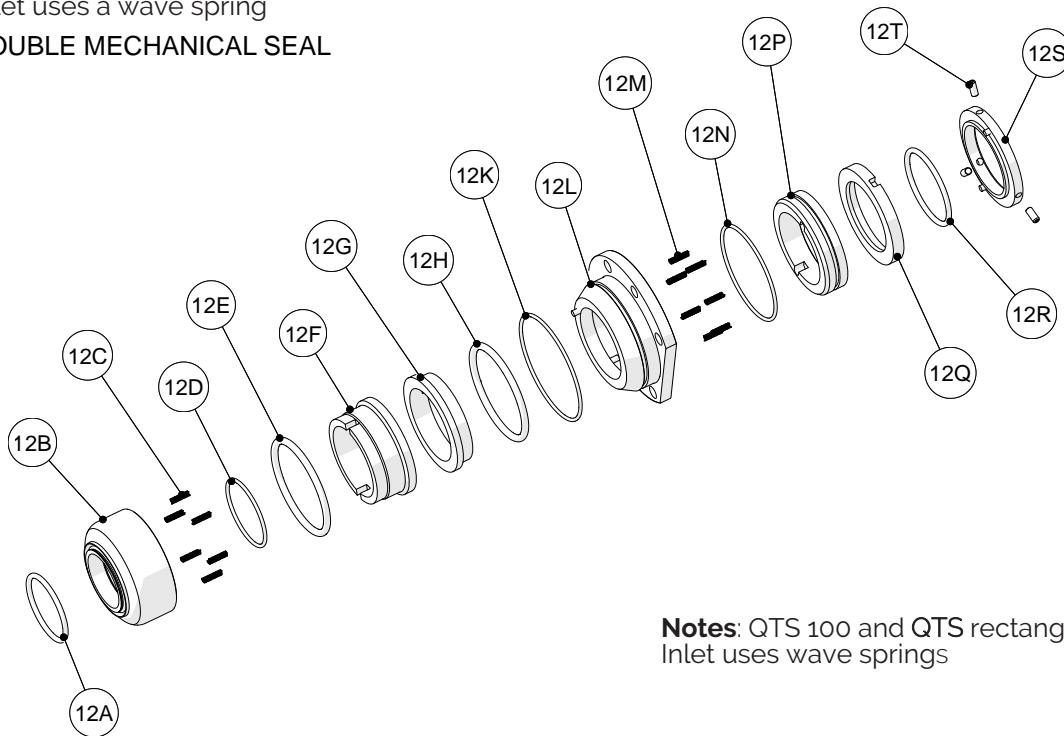

Notes: QTS 100 and QTS rectangular Inlet uses wave springs

Single mechanical seal kit: it contains components **12A** to **12J**.

Double mechanical seal kit: It contains all components of the single mechanical seal plus components **12K** to **12T**; in this case the stainless steel seal housing (**12J**) is replaced by the seal housing (**12L**) which is already included on the double mechanical seal kit.

The mechanical seal should be installed using your hands only. No special tools are required unless it is indicated. You may use a hook to take out the O-rings from their grooves. Be careful not to scratch the seal faces.

Look for defects on the sealing surfaces such as scratches or wear. If a replacement is necessary, it is recommended to change all components to ensure proper operation. If an O-rings is deformed or damaged it is recommended also to replace the entire set of O-rings.

Uninstalling the Single Mechanical Seals

1. Remove with your hands the stainless steel rotary holder subassembly **(12B-F)** by grabbing and pulling out from the rotating face **(12F)**. When pulling, the static face **(12G)** might come along.
2. To inspect the O-rings inside, remove the rotating face pulling gently out the rotary holder; inside are the springs **(12C)** and the O-ring **(12D)**, be careful because the springs are loose. Finally remove the O-ring **(12E)** which is on the rotary holder groove.
3. Remove the O-ring **(12A)** housed in the rotary holder on the front groove. Sometimes O-rings can be loose out of their grooves and get stuck to other components.
4. On the back cover **(5)** pull out the static face **(12G)** and the O-ring **(12H)**. Avoid any harsh contact on the sealing faces.
5. To remove the seal housing **(12J)** it is necessary to remove the back cover of the pump.
6. Loosen the hexagonal socket head cap screws **(28)** that fix the back cover to the bearing housing **(6)** and extract it through the studs **(14)**. The back cover is centered with dowel pins **(25)**, this pins can go out along with the back cover or can stay in the bearing housing as well.
7. Loosen the hexagonal socket head cap screws **(13)** on the back of the cover to eject the seal housing. Push with your thumbs from the front of the back cover. Be careful when removing the seal housing to avoid any harsh contact. This step is not necessary if only a seal replacement is needed
8. Repeat these steps to disassemble the other mechanical seal.

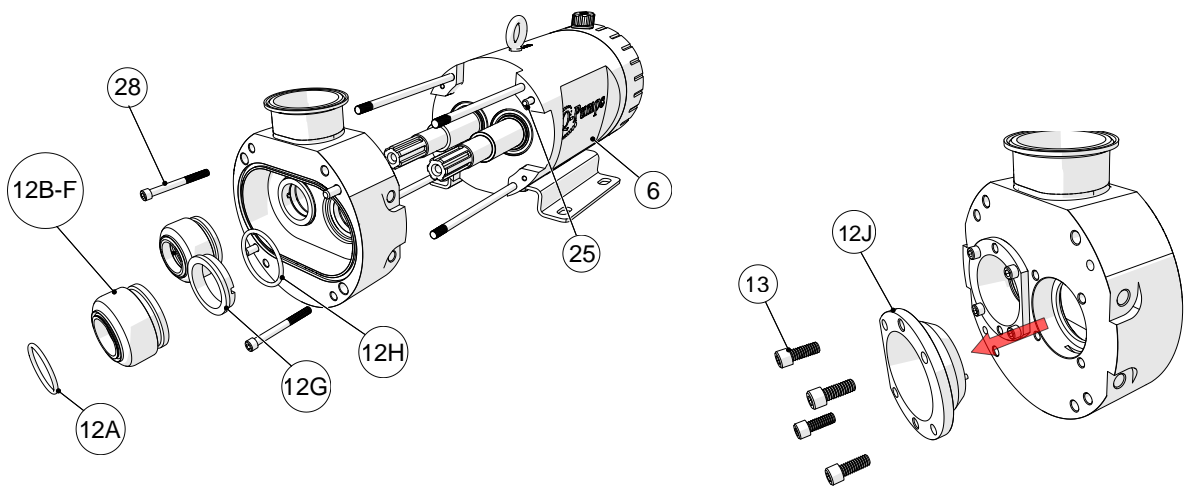

Installing the Single Mechanical Seals

You do not require special tools to install the mechanical seals, use your hands to assemble the components.

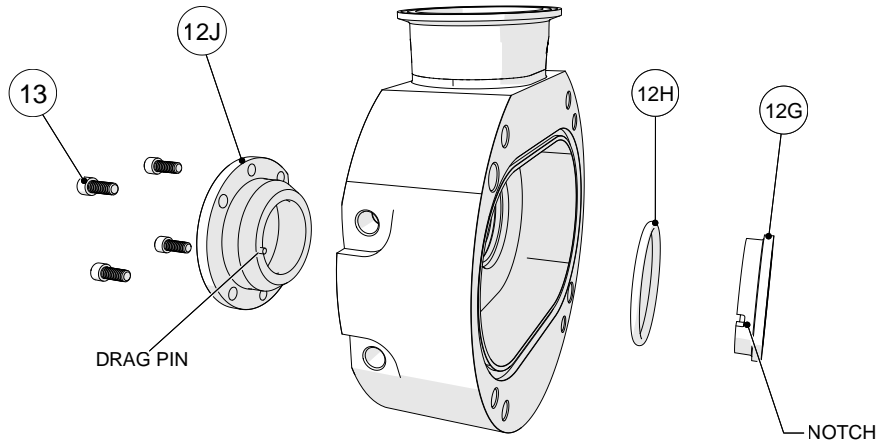

1. Place the dowel pins **(25)** on the bearing housing, slide them smoothly, if you find difficulties stop and check the surface finish of the pins and the bores on the bearing housing; replace the pins if necessary and clean the inside bore (may use a scrub or a sponge).
2. Place the seal housing **(12J)** into the back cover. It has a drag pin in the front for the static face **(12G)**
3. Tighten the button head screws **(13)** to secure the seal housing in the back cover.
4. Place the O-ring **(12H)** on the box of the back cover **(5)**.
5. Proceed to place the static face **(12G)** in the back cover. Make sure the notch is aligned with the drag pin. There is no physical contact between the static face and the seal housing, the O-ring limits the position of the static face. This step is crucial for the right assembly of the mechanical seal; failing to do so properly can cause damage to the mechanical seals and to the rotors.

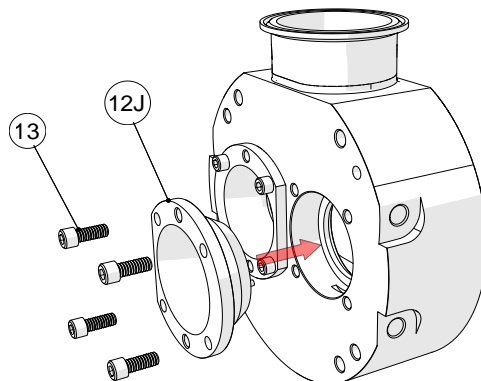

7. Repeat this procedure with the seal housing.

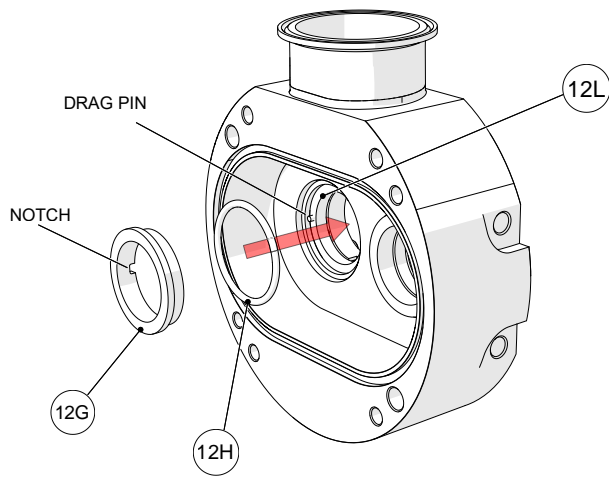

8. Take the back cover (with the seal housings inside) and carefully slide along the studs and shafts pushing it to the back until making contact with the bearing housing; use the dowel pins to center it with the bearing housing.

WARNING! All four dowel pins must always be placed before running the pump. Not doing so will cause severe damage to the pump.

9. Fix the back cover to the bearing housing with the hexagonal socket head cap screws (28) and tighten them firmly.

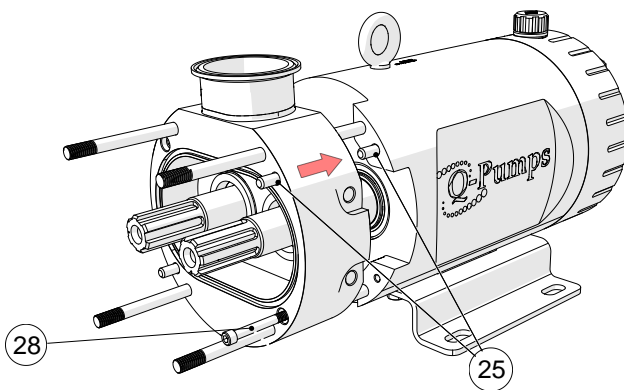

10. Place the O-ring (12D) on the inside groove of the stainless steel holder (12B). Insert the springs (12C) on the inside bores on the holder.

11. Lubricate the inside diameter of the O-ring (12E) and place it on the inside groove of the holder and make sure it is fixed.

12. Take the rotating face (12F) and insert it into the O-ring; the holder pins must fit the notches on the rotating face. Push with your hand against the holder until the springs are compressed and the rotating component stays inside the holder.

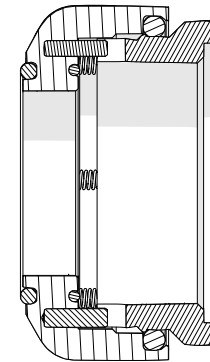
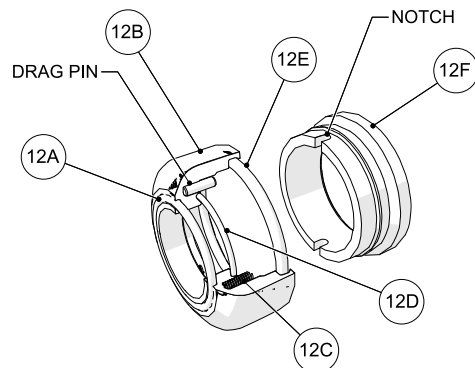

NOTE: It is important that the notches of the rotating face fit the holder pins; the physical contact is lead by the O-ring and the springs with no contact between metal and the rotating face. This step is crucial for the right assembly of the mechanical seal; failing to do so properly can cause damage to the mechanical seals and the rotors.

13. Place the O-ring **(12A)** into the holder front groove. This completes the subassembly of the rotating part of the seal.

14. With the subassembly ready, insert the rotary holder on the shaft and push smoothly until it reaches the static face placed previously on the back cover. Repeat this procedure to install the other single mechanical seal on the next shaft.

15. At this point you have already assembled the single mechanical seals, continue with the assembly of the rotor.

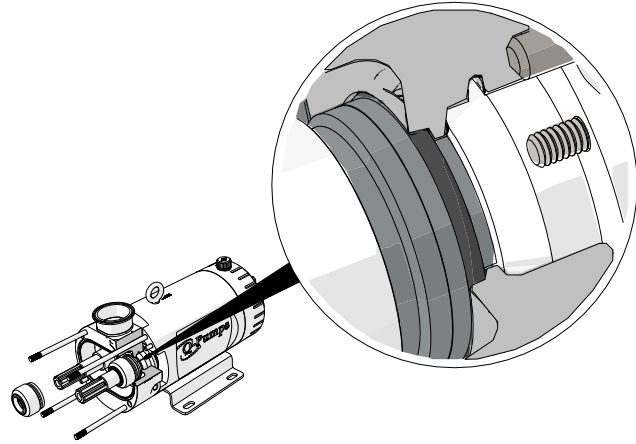

Uninstalling the Double Mechanical Seals

1. Remove with the hand the stainless steel rotary holder subassembly **(12B-F)** by grabbing and pulling out from the rotating face **(12F)**. When pulling, the static face **(12G)** might come together.

2. To inspect the O-rings inside, remove the rotating face pulling gently out the rotary holder; inside are the springs **(12C)** and the O-ring **(12D)**, be careful because the springs are free. Finally remove the O-ring **(12E)** which is on the rotary holder groove.

3. Remove the O-ring (12A) housed in the rotary holder on the front groove. Sometimes O-rings can be loose out of their grooves and get stuck to other components.

4. On the back cover **(5)** side pull out the static face **(12G)** and the O-ring **(12H)**. Avoid any harsh contact on the sealing faces.

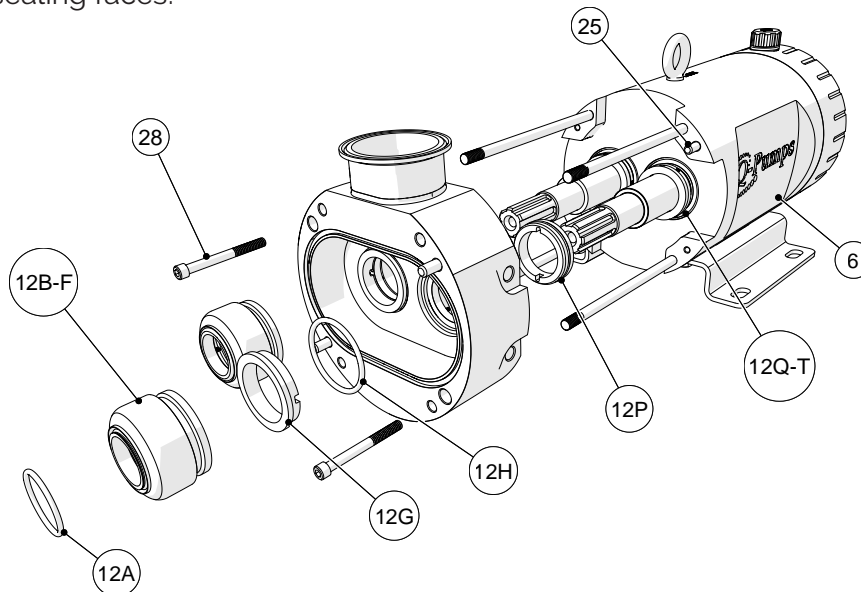

5. To remove the seal housing **(12L)**, O-rings **(12K and 12N)**, springs **(12L)** and the static face of

secondary seal **(12P)** it is necessary to remove the back cover of the pump.

6. Loosen the hexagonal socket head cap screws **(28)** that fix the back cover to the bearing housing **(6)** and extract it through the studs. The back cover is centered by dowel pins **(25)**, this pins can come out with the back cover or stay in the bearing housing.

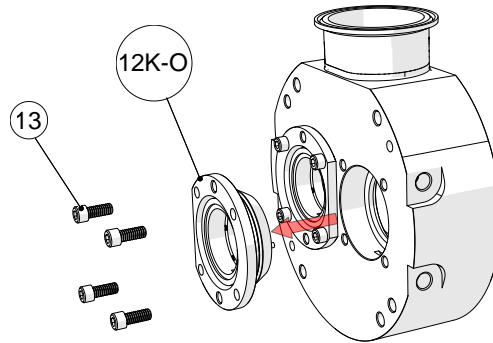

7. When extracting the back cover it is possible that the rotating face **(12Q)** comes attached to the secondary static face **(12P)**; handle it with care to prevent any harsh contact to the seal faces with the shafts.

8. Loosen the hexagonal socket head cap screws **(13)** on the back of the cover to eject the seal housing. Push with your thumbs from the front of the back cover. Be careful when removing the housing to avoid any harsh contact.

9. Take away the O-ring **(12K)** on the housing using the O-ring hook.

10. To remove the static face of the secondary mechanical seal **(12P)** hold the housing with the static face looking up and pull with your thumbs.

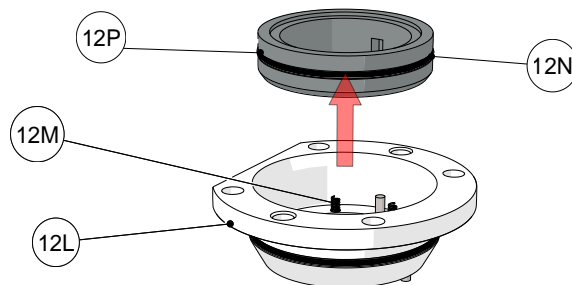

NOTE: Always place the seal face looking up to prevent the springs from falling out.

11. Using the O-ring hook, remove the O-ring **(12N)**. Remove the springs **(12M)** if necessary.

12. To extract the rotating components of the secondary mechanical seal pull out of the shaft the seal face **(12Q)** and remove the O-ring **(12R)** located inside this rotating seal face.

13. With a hexagonal key, loosen the set screws **(12T)** from the drive ring **(12S)** and pull it out if needed.

14. Repeat these steps to uninstall the rest of the components of the other double mechanical

seal.

Installing the Double Mechanical Seals

1. You do not require special tools to install the mechanical seals, use your hands to place the components into the assembly.
2. Place the dowel pins **(25)** on the bearing housing, slide them smoothly, if you find difficulties stop and check the surface finish of the pins and the bores on the bearing housing; replace the pins if necessary and clean the inside bores (may use scrub sponge).
3. Place the set screws **(12T)** in the drive ring **(12S)** using a hexagonal key. The screws must not pass through the inner diameter of the drive ring. Slide the ring on the shafts until the end shoulder and tight the set screws.
4. Insert the O-ring **(12R)** into the groove on the rotating face of the secondary mechanical seal **(12Q)** and slide them together on the shafts until reaching the drive ring. Make sure the drag pins fit the notches on the rotating face.

NOTE: For ease of assembly, you can lubricate the O-rings with an FDA approved silicone grease

5. Repeat these two last steps with the other rotating components of the double mechanical seal.

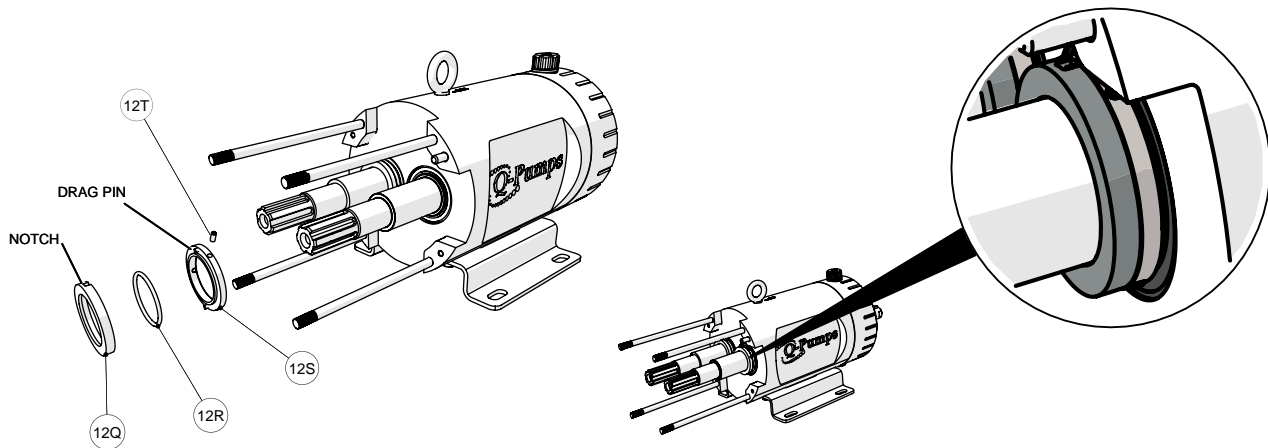

6. The seal housing **(12L)** has a drag pin in the front for the static face of the primary mechanical seal **(12G)** and drag pins on the inside for the static face of the secondary mechanical seal **(12P)**.
7. Place O-ring **(12K)** in the outside groove of the seal housing **(12L)**.
8. Continue placing the springs **(12M)** inside the seal housing.

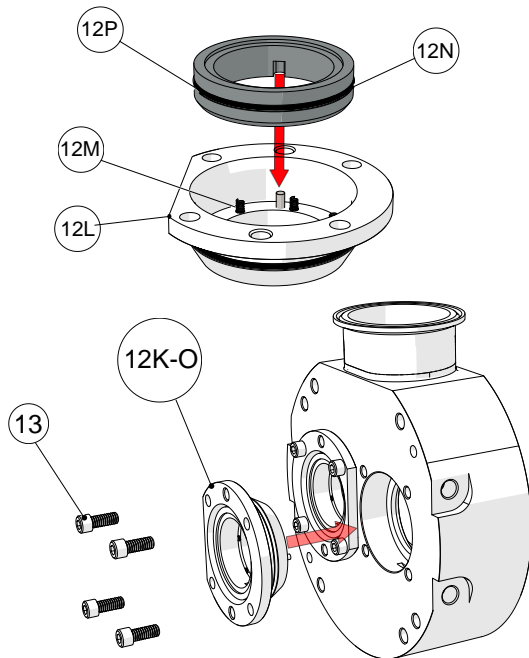

9. Place the O-ring **(12N)** on the static face of the secondary seal **(12P)** and insert it on the seal housing **(12L)**; match the notches with the pins on it. Press evenly with both hands until the element gets completely inside the housing. If the pins are not aligned with the notches the element can be damaged; the final position is given by the spring and the O-ring so there should be no contact between metal and the static face of the secondary mechanical seal.

10. Continue placing the seal housings (with seal faces and O-rings) inside the back cover **(5)**.

11. Tighten the hexagonal socket head cap screws **(13)** to secure the seal housing in the back cover.

12. Repeat this procedure with the next seal housing.

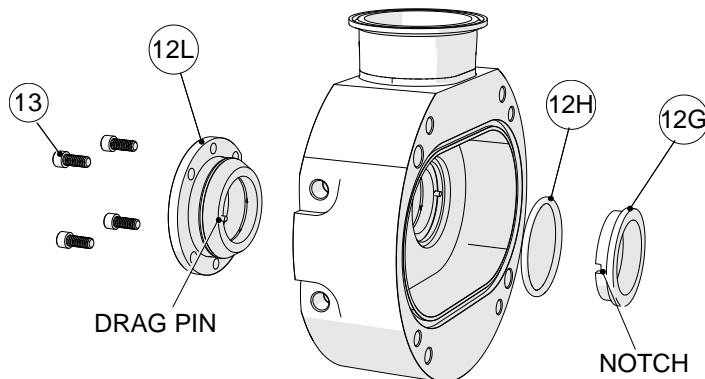

13. Place the O-ring **(12H)** on the box of the back cover **(5)**.

14. Proceed to place the static face **(12G)** in the back cover. Make sure the notch is aligned with the drag pin. There is no physical contact between the static face and the seal housing, the O-ring limits the position of the static face. This step is crucial for the right assembly of the mechanical seal; failing to do so properly can cause damage to the mechanical seals and the rotors.

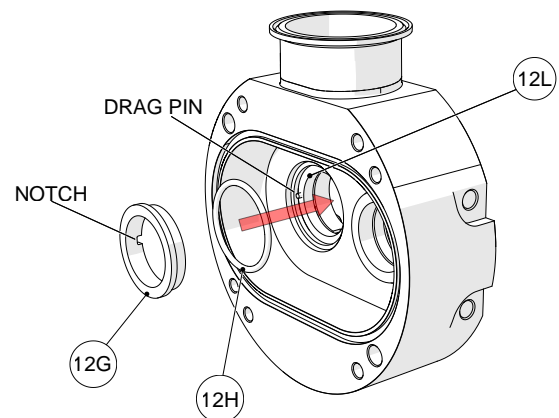

15. Take the back cover (with the seal housing inside) and carefully slide thru the studs and shafts pushing it to the back until making contact with the secondary rotating face **(12Q)** ; use the dowel pins to center the part with the bearing housing.

WARNING! All four dowel pins must always be placed before running the pump. Not doing so will cause severe damage to the pump.

16. Fix the back cover to the bearing housing with the hexagonal socket head cap screws **(28)** and tighten them firmly, the secondary seal springs will compress as you tight.

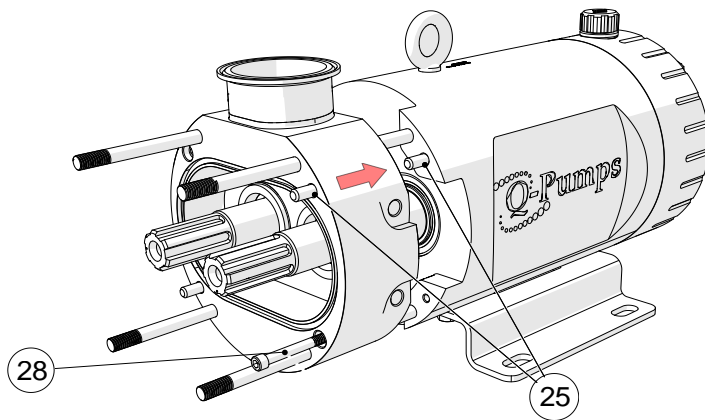

17. Place the O-ring **(12D)** on the inside groove of the stainless steel rotary holder **(12B)**. Insert the coil springs **(12C)** on the inside bores of the holder.

18. Lubricate the inside diameter of the O-ring **(12E)** and place it on the inside groove of the holder and make sure it is fixed.

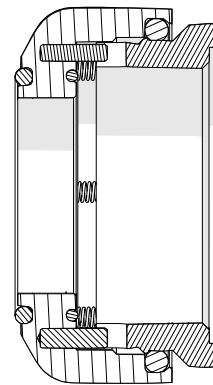
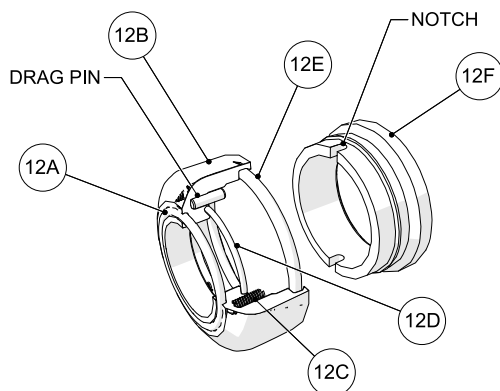

19. Take the rotating face **(12F)** and insert it into the O-ring; the holder pins must fit the notches on the rotating face. Push with your hand against the holder until the springs are compressed and the rotating component stay inside the holder.

NOTE: It is important that the notches on the rotating face fit the holder pins; the physical contact is determinate by the O-ring and the springs with no contact between metal and the rotating face. This step is crucial for the right assembly of the mechanical seal; failure to do so properly can cause damage to the mechanical seals and the rotors.

20. Place the O-ring **(12A)** into the holder front groove to finish the rotary holder subassembly.

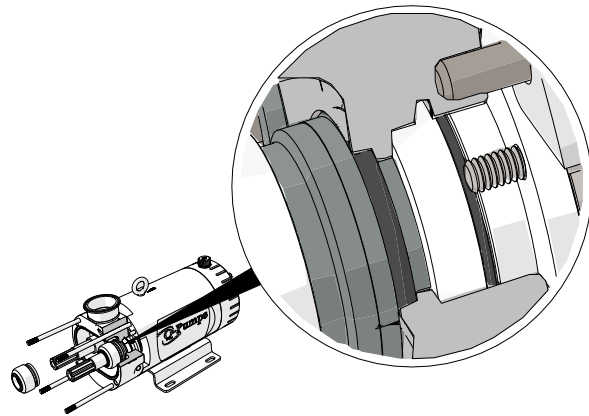

21. With the subassembly ready, insert the rotary holder on the shaft and push smoothly until reach the static face placed previously on the back cover. Repeat this procedure to install the other primary mechanical seal on the next shaft.

ATTENTION: Remember that every double mechanical seal requires lubrication without exception. Place the flush nipples **(53)**, one on each side of the back cover, the bottom works as the inlet and the top as the outlet of the lubricant fluid for each seal.

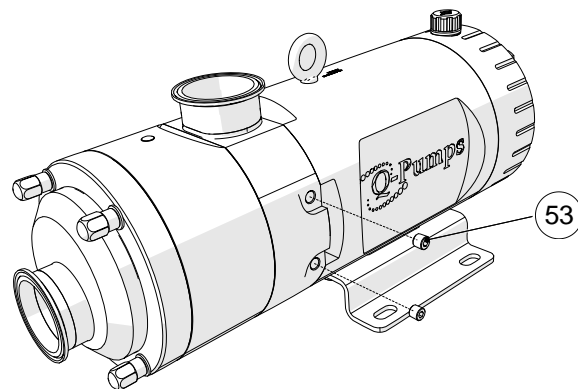

22. At this point you have already assembled the double mechanical seals, now continue with the assembly of the rotors.

Rotor Assembly

1. Make sure the mechanical seals are properly installed before assembling the rotors. If the studs **(14)** were removed place them back. Insert firmly the gasket **(27)** on the back cover groove.

NOTE: To place the studs you may use the nut-and-locknut technique (see annex B).

2. Shafts and rotors are marked on the front face with dots to indicate the position of the rotor relative to the spline on the shaft; the rotors are also marked to identify which is the right rotor **(3)** and the left rotor **(2)**, it is important to match each rotor with its respective shaft for the right operation of the pump.

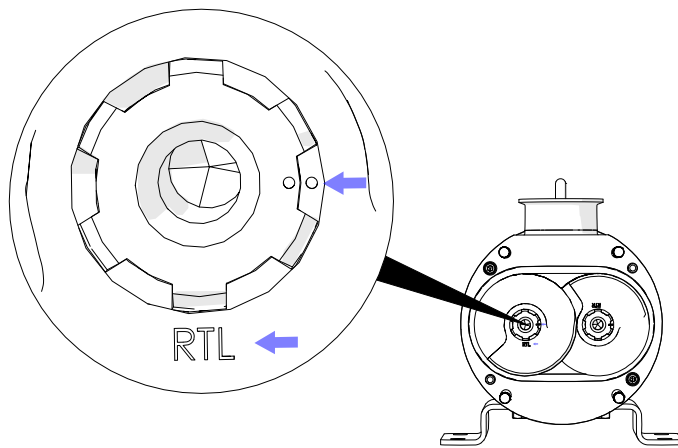

3. Take both rotors together with your hands and mesh them so the front faces are leveled. Turn the drive shaft to the marks of the meshed rotors **(9)** and the rotors so the dots correspond.

4. Slide the rotors together onto the shafts. Some alignment might be needed. By effect of the mechanical seals the rotors have not yet reached their final position; it is necessary to tighten the nuts.

5. Place the set screws **(24)**, the spring washers **(23)** and the O-rings **(26)** on the rotor nuts **(11)**. Tighten the rotor nuts as follows:

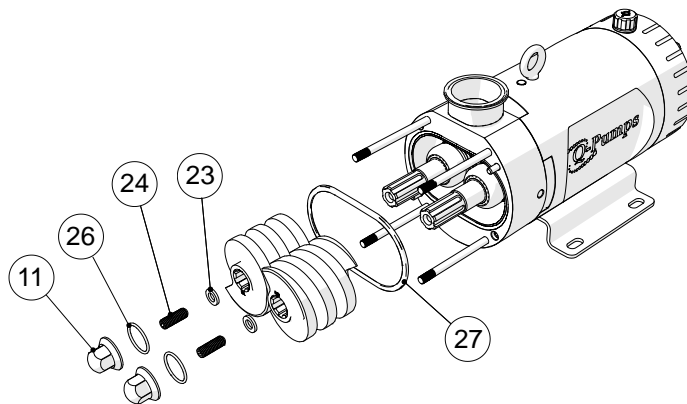

6. Block the drive shaft **(9)** with the aid of a wrench to prevent rotation of the rotors.

7. Tighten by hand the rotor nuts **(11)** simultaneously as far as you can; then use a six points socket to tighten the nuts. Gradually tighten both nuts simultaneously to avoid contact between rotors.

8. When the rotors reach their end position with the mechanical seals and shafts, tighten the nuts with the torque values according to the pump model. The front faces of the rotors should be aligned.

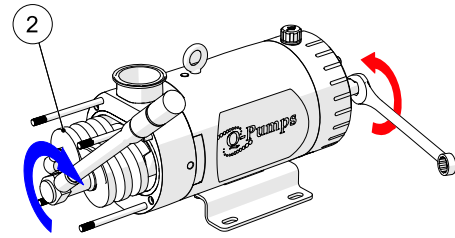
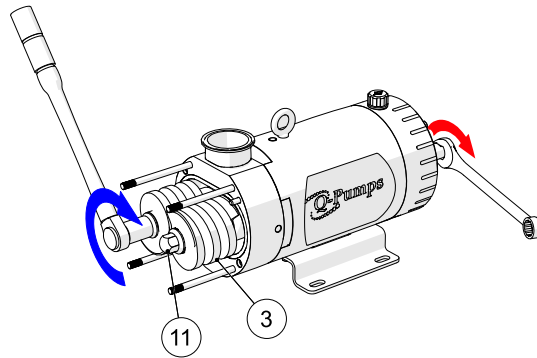

9. Using thickness gages, check the clearances between the rotors turning them slowly and introducing one gage at every point where the rotors are meshed. A practical way to do it is sliding the gage between the rotors in the front side and slowly rotate them so the gage moves along the rotors by its rotation. If the clearances do not comply (according to the pump model) is probable that the synchronization is not correct.

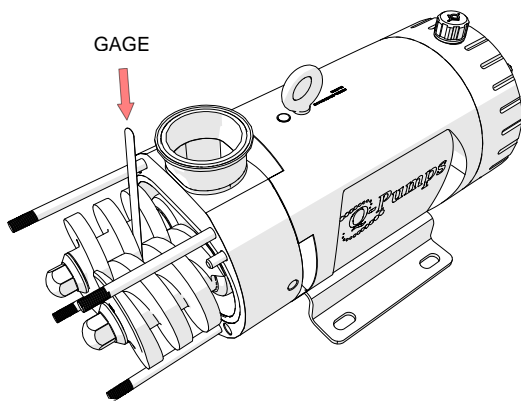

10. Once you have tightened and checked the rotor clearances continue closing the pump. Place the dowel pins **(25)** inside the holes on the back cover.

WARNING! Dowel pins must always be placed before running the pump. Not doing so will cause severe damage to the pump.

11. Insert the casing **(4)** carefully, it should be mounted and centered on the back cover **(5)** with the dowel pins. Push back to slide through the studs **(14)**. The plug **(53)** covers a threaded bore that can be used to lift the part in larger models.

12. Insert gasket **(27)** into the groove on the front cover (1) and close the pump; use the pocket in the front cover as a guide for assembling it with the casing.

13. Secure the front cover with the washers **(22)** and nuts **(21)**; tighten using a wrench or a six points female socket. Remember to use the corresponding torque values according to the pump model. This concludes the rotor assembly.

If you need any advice to assembly and/or disassembly, please contact your distributor or **Q-Pumps**.

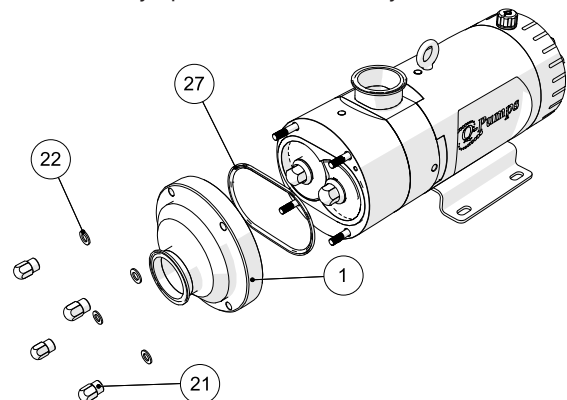
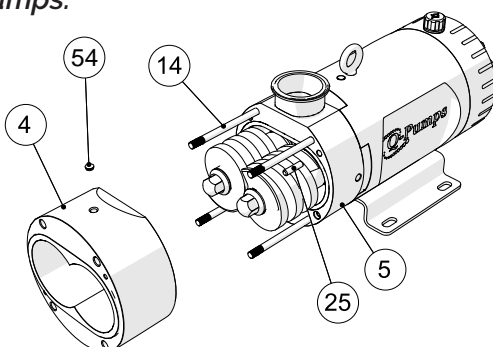

Rotor Synchronization

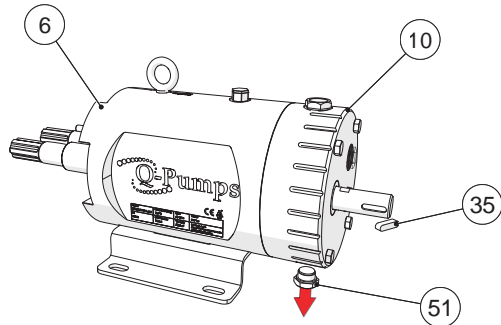

1. Once the pump is disassembled, proceed to drain the oil in the gearbox. Use the cap nut **(51)** on the bottom of the gear case **(10)**. If the oil is in good condition, keep it in a closed reservoir in order to avoid contamination. If the oil is dirty change it with new one. View oil section **(page 15)**.

2. Remove the coupling key **(35)** from the drive shaft **(9)**.

3. Loosen the hexagonal bolts **(33)** and pull back the gear case. Inside are the gears that drive the pump. The drive gear **(41)** is driven with a key, while the driven gear **(42)** is locked by tapered rings.

Note: The tapered rings while loosen will make the idle gear rotate without transmitting any motion to the shaft. If the tapered rings are tighten, the driven gear will rotate with the shaft.

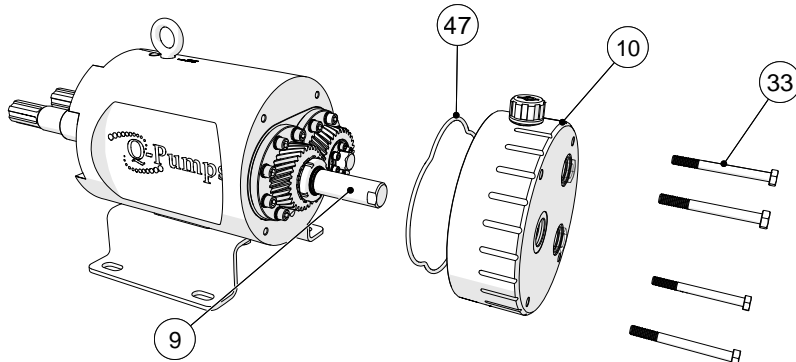

4. Undo the socket head cap screws **(46)** and remove them all. All screws have a lock washer **(45)**

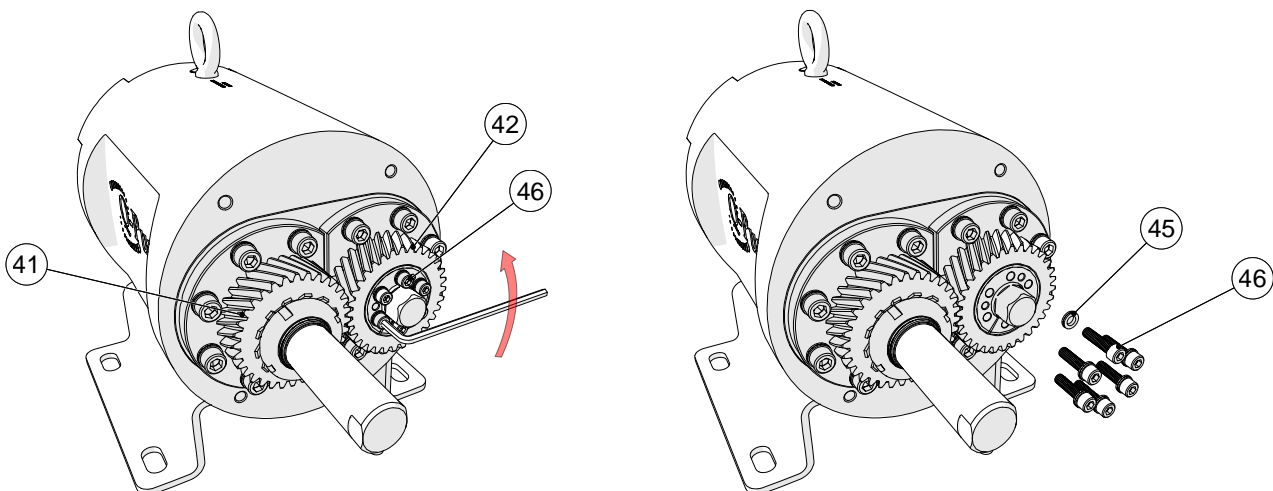

- To loosen the tapered driven ring **(20)** it is necessary to use three of the socket head cap screw **(46)** to push it out as illustrated. The first tapered driven ring has three threads for this purpose.
- Pull out the tapered driven ring **(20)**. On the inside there will be the tapered drive ring **(18)**. By doing this the driven gear **(42)** will loosen and move freely over the synchronization ring **(19)**

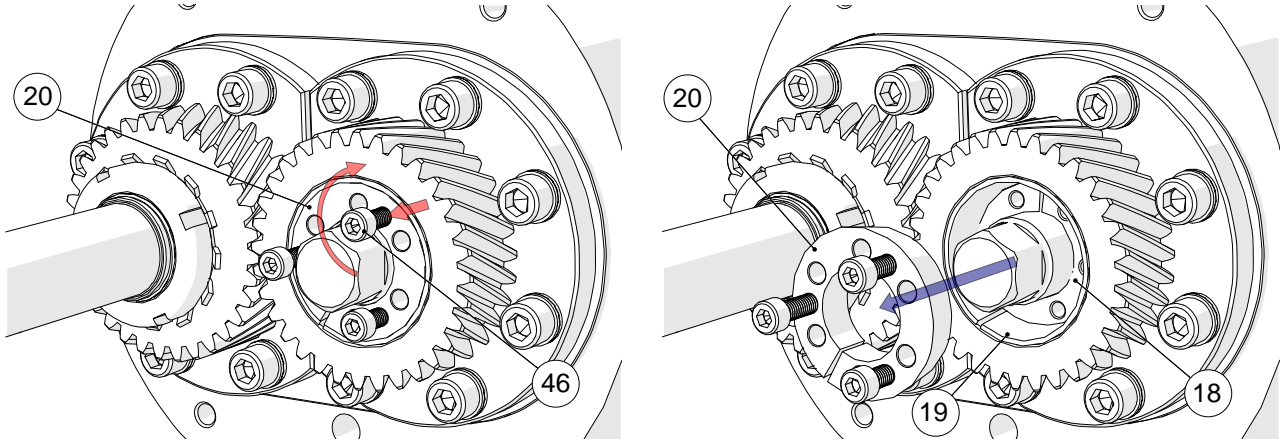

- On the pump side place both rotary holder subassemblies **(12A-F)** on the shafts. In this step it is not necessary to assemble the complete seals, it is just a preliminary assembly to set position. It is recommended to remove the O-rings **(12A and 12D)** in the subassembly.
- Take the new rotors with each hand respectively [left hand-left rotor **(2)** / right hand-right rotor **(3)**] and mesh them together. The front faces of both rotors must be at the same level.

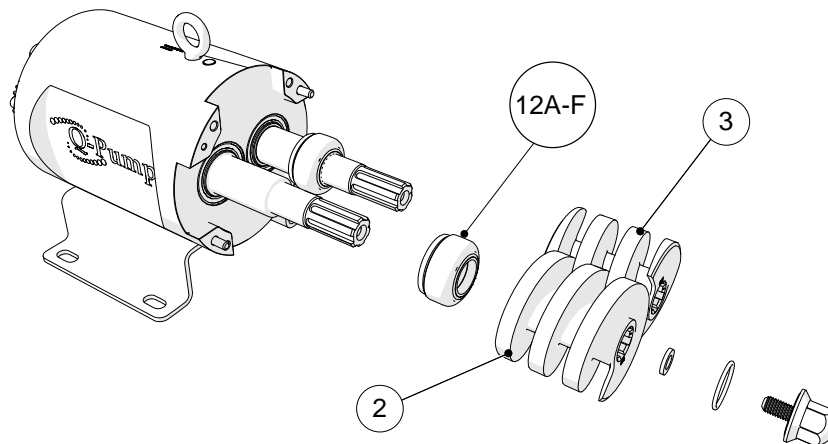

- With the rotors meshed, place them in the shafts. Turn the shafts until the splines coincide. There are no marks in the rotors yet.
- Push the rotors on the shaft until they reach each rotary holder subassembly. Place the rotor nuts **(11)** and thigh them simultaneously until each rotary holder is pressed. You may have to turn the rotors to create space for tightening, avoid contact between rotors. View torque table.

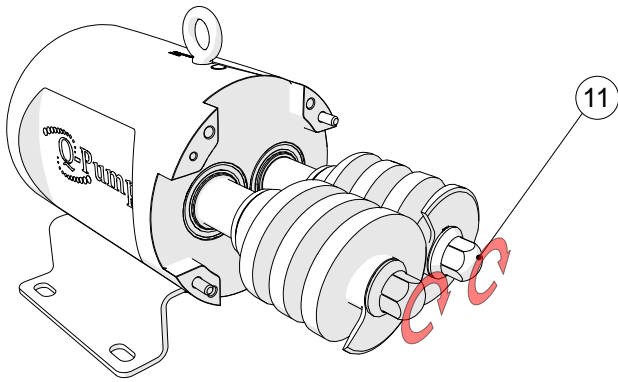

11. At this point the rotors move independently. Insert a thickness gage at both flanks between rotors to synchronize them. View the thickness gage table.

12. On the back of the pump, align the tapered rings together. Push the tapered drive ring (18) to make the driven gear (42) touch the shaft shoulder and insert the tapered driven ring (20) back on the shaft. Use a flat screwdriver if needed to open the ring. Do not tighten yet.

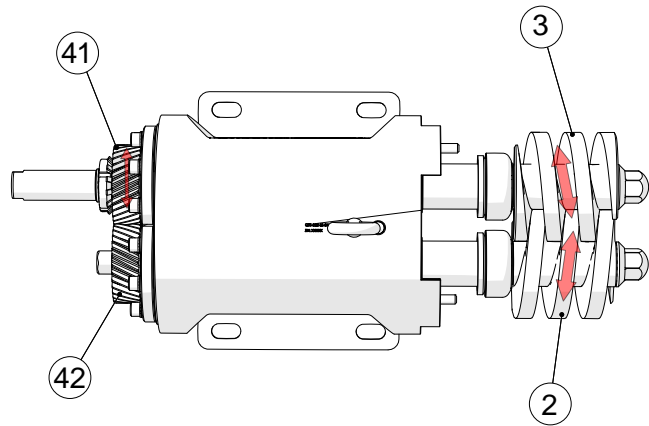

13. On the front of the pump, equally distribute the space between flanks using the thickness gages in both sides. Avoid excess of gage compression while synchronizing the rotors.

14. Proceed to tighten the tapered driven ring (20). Tighten the socket head cap screws (46) uniformly, by alternating between them until the maximum torque is reached. View torque table.

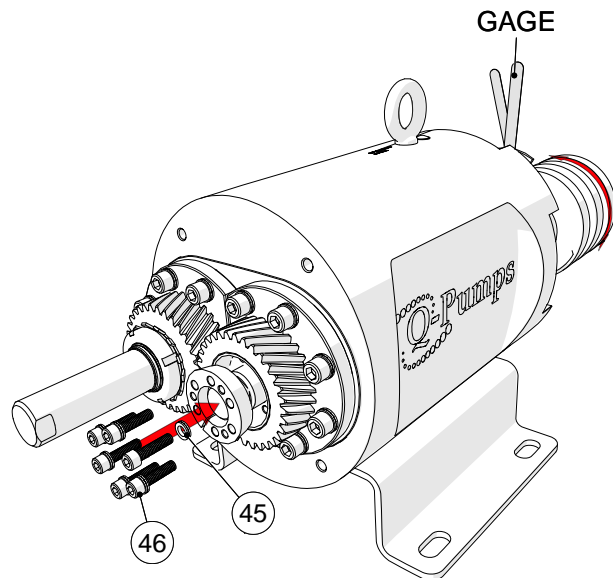
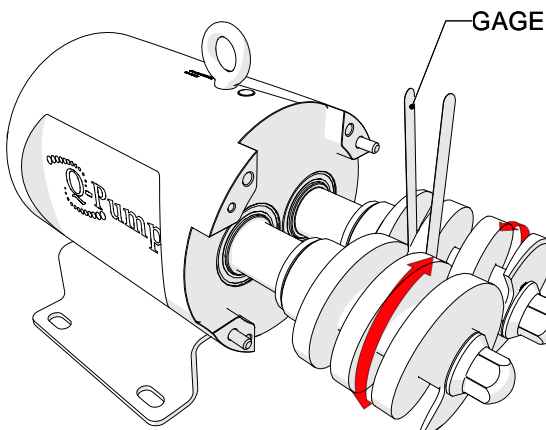

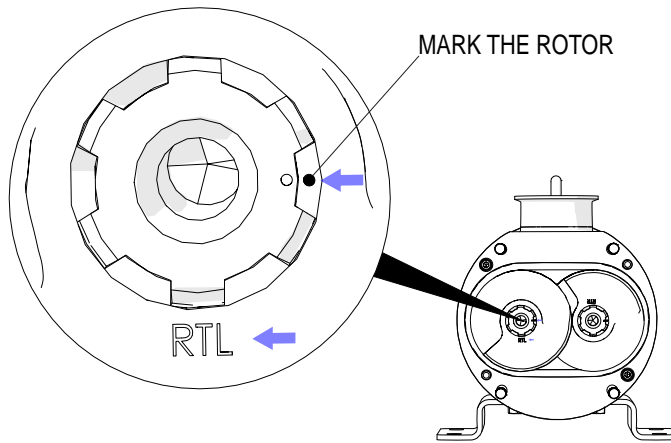

15. At this point gears are locked, rotors are synchronized and you can remove the thickness gages.

16. Undo the rotor nuts **(11)** and mark the rotors with their corresponding marks on the shaft using indelible ink or by making a notch. View original rotors spline as example.

17. Remove the rotors and rotary holder subassemblies.

18. Assemble the gear case **(10)** and fill it with oil. View page 14

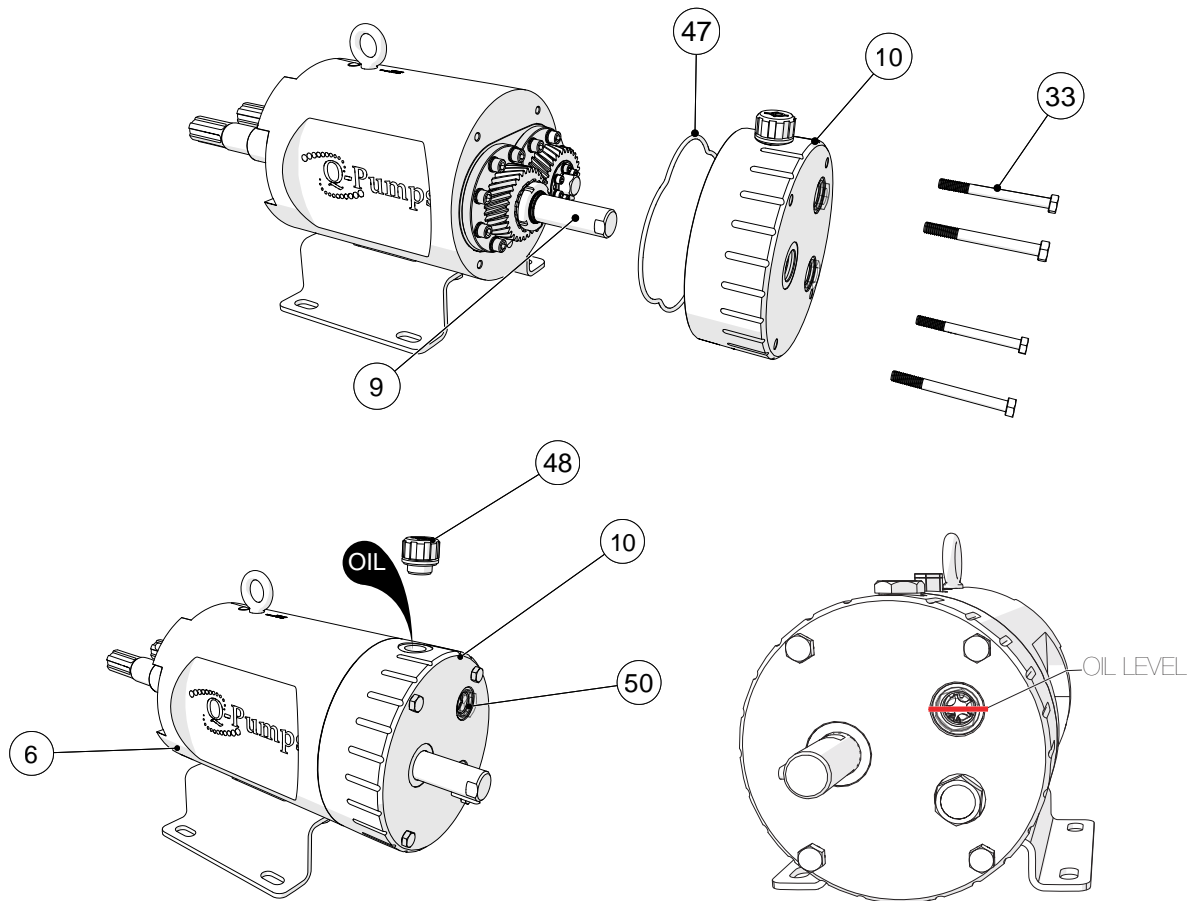

19. Continue to assemble the pump, described in the Seal Assembly and Rotor Assembly section.

Bearing replacement

Drive shaft disassembly

1. The drive gear **(41)** is locked by a lock nut **(44)** and a lock washer **(43)**. Use a flat screw driver or a chisel to bend the tab to allow the locknut to rotate.
2. Use a hook spanner or the special QTS adapter (provided in the QTS tool bag) to loosen the lock nut.

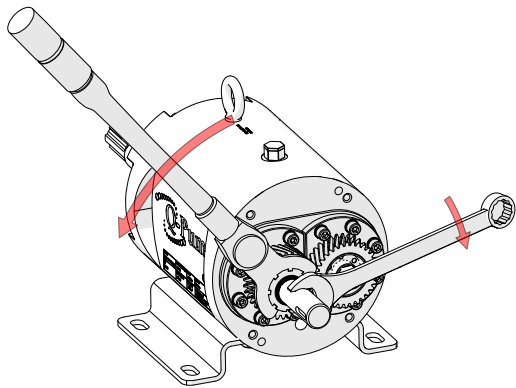
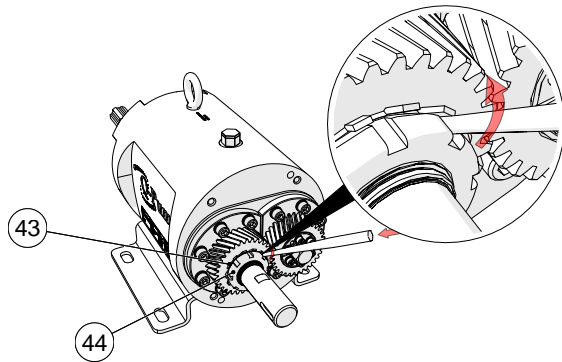

3. Remove the lock nut and the lock washer. At this moment the drive gear can be taken out with its key **(34)**. If necessary, use pliers to remove the key.

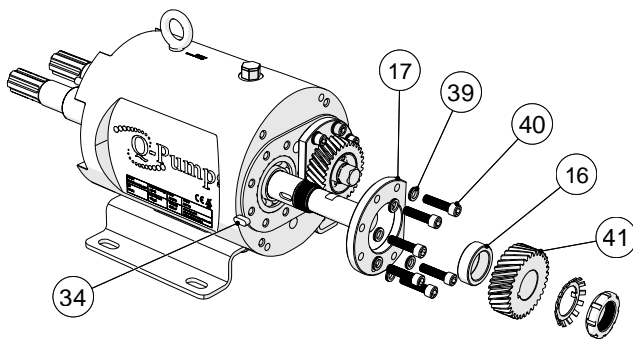

4. Take out the gear spacer **(16)**.
5. Loosen and remove the screws **(40)** to take away the retention flange **(17)**.
6. Pull out the drive shaft. If necessary, use a mallet at the other end.

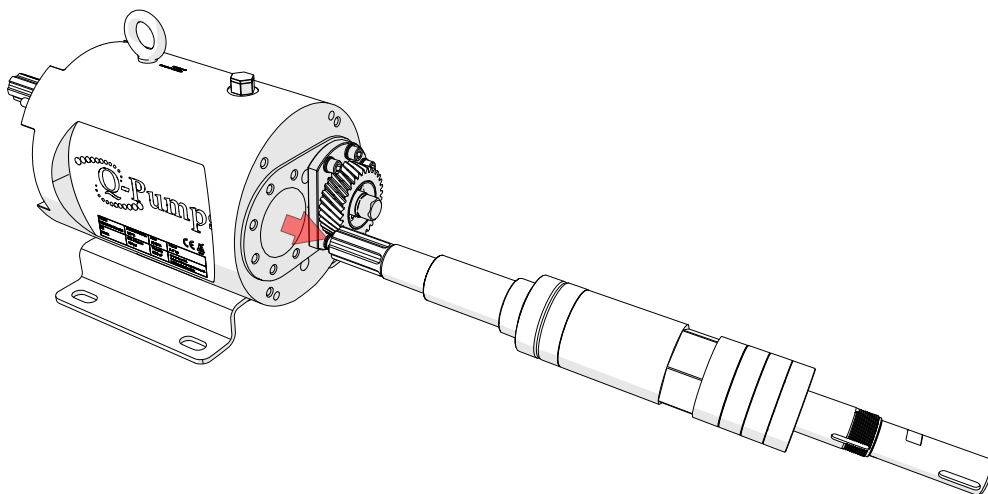

Driven shaft disassembly

1. The driven gear (42) is locked to the shaft by the tapered rings (18-19-20). Loosen the screws (46) to loosen the tapered rings. If necessary, use the threads in the drive tapered ring (20) to push it out.
2. Pull out the driven gear. The tapered rings will come out too.
3. Loosen and remove the screws (40) to take away the retention flange (17).
4. The bearings are held in position by a lock nut (44) and a lock washer (43). Use a flat screw driver or a chisel to bend the tab to allow the locknut to rotate.

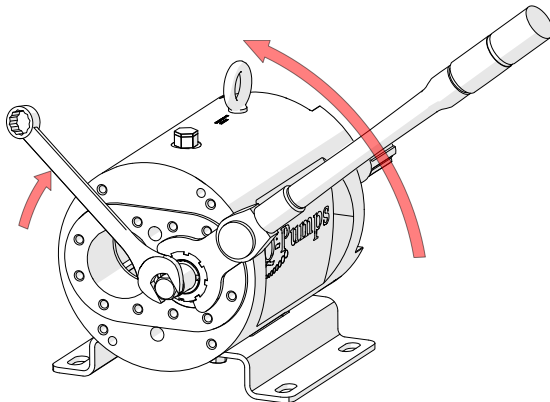
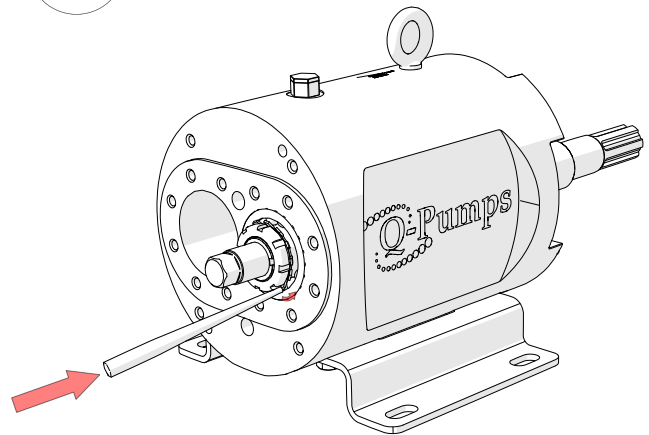
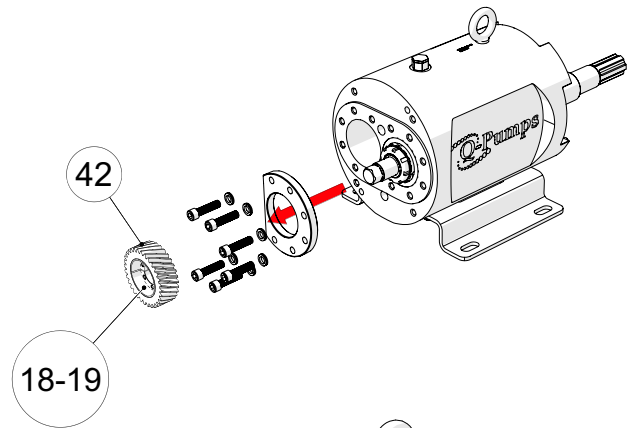

5. Use a hook spanner or the special QTS adapter (provided in the QTS tool bag) to loosen the lock nut. It is necessary to do this step now to have a good support to loosen.

6. Pull out the driven shaft. If necessary, use a mallet at the other end.

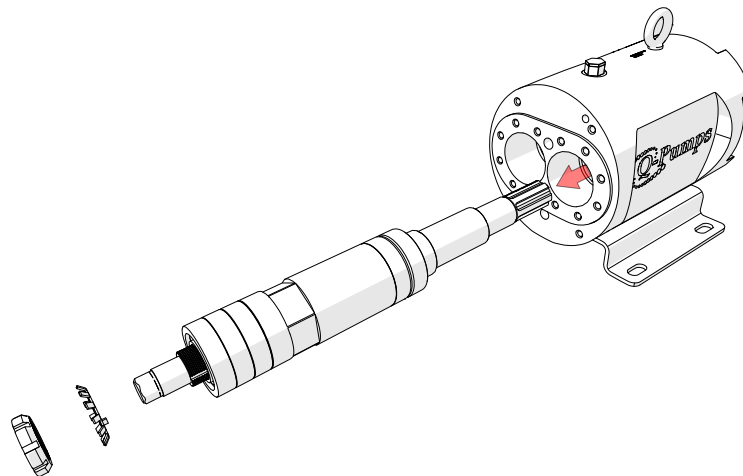

Bearing Arrangement and Replacement

The change of bearings is needed when the shafts have axial or radial play greater than permissible. This play has to be measured and if it exceeds .006 in in radial play and .003 in in axial play, bearing change is needed. Other signs that indicate bearing change is noise, rust or rotors contact within the pump ratings.

The QTS uses two types of bearings per shaft, one needle bearing (37) in the front and three angular contact ball bearings (38) in the back and are separated by a bearing spacer (15). The needle bearings has an internal race that is kept in position by retaining rings (36). The ball bearings have to be arranged depending on the main operating conditions of the pump. The following image shows the two possible configurations.

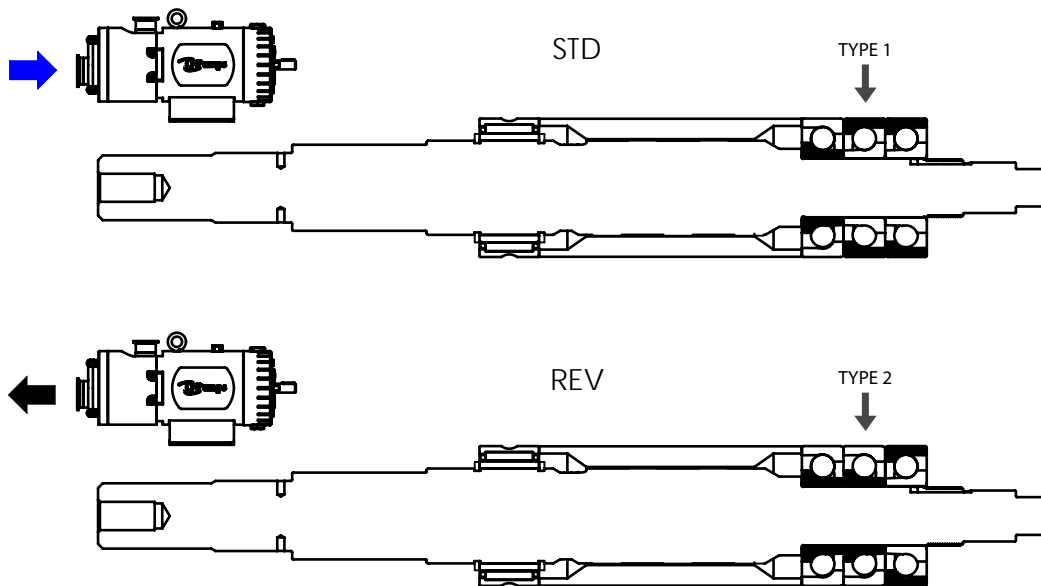

Bearing removal

1. In the front side of the shaft, remove the retaining ring (36).
2. Slide out the external race of the needle bearing (37).
3. Remove angular contact ball bearings with the aid of an extractor. Support only the bearing inner race (15) and avoid damage to the shaft.

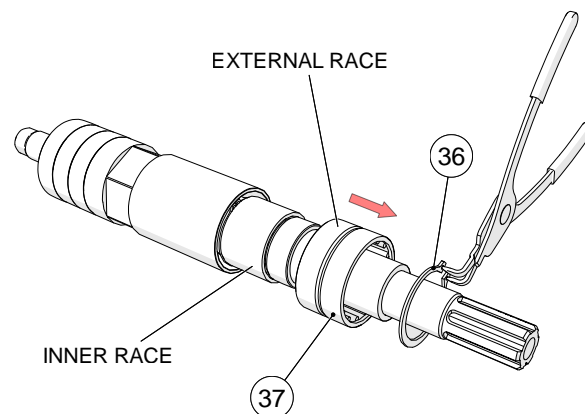

IMPORTANT: The shaft needs to have enough clearance to move out without scratching.

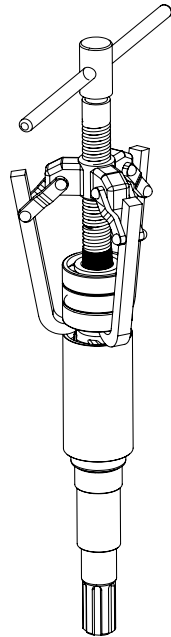

5. Take out the bearing spacer and take out the remaining retaining ring.

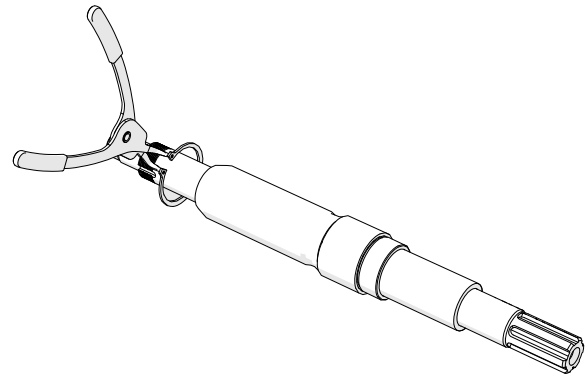
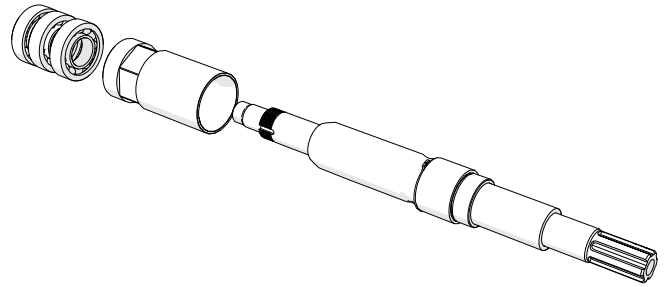

6. Place the shaft front side down on the press to remove the internal race of the needle bearing. Support only the internal race.

IMPORTANT: Use similar diameter rings or "V" blocks of softer metal to avoid damage to the shaft. The shaft needs to have enough clearance to move out without scratching.

7. Press at the center of the shaft until the internal race slides out.

IMPORTANT: Use a soft metal between the piston and the shaft to avoid marking it. The shaft has to be held to avoid falling down.

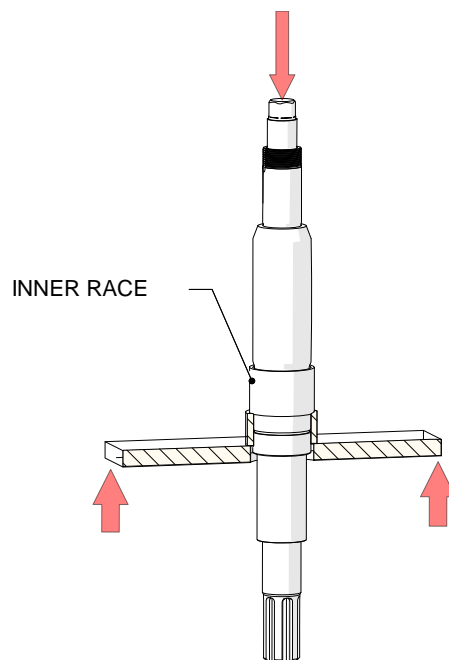

Bearing Assembly

1. On the front side of the shaft, place the retaining ring (36) in the second groove.

2. Insert the needle bearing (37) inner race in the shaft until it stops. Place the inner race in the hydraulic press supported in a metal ring of similar internal diameter.

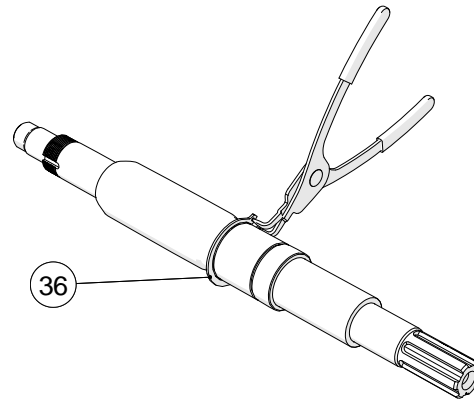

IMPORTANT: Use similar diameter rings or “V” blocks of softer metal to avoid damage to the shaft. The shaft needs to have enough clearance to move in without scratching.

3. Press the shaft until the inner race touches the retaining ring.

IMPORTANT: The inner race must be centered between the two grooves. The retaining rings must not be compressed. Use a soft piece of metal to avoid marking the shaft.

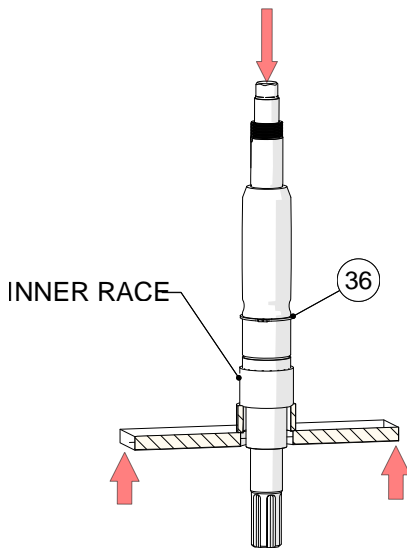

4. Identify the thinner side of the bearing spacer (15) and insert it from the back of the shaft until it reaches the retaining ring.

5. Place the shaft in the press supporting it with its first shoulder.

IMPORTANT: Use a plate or “V” blocks of soft metal to avoid marking the shaft.

CAUTION: Do not deform the shaft shoulder as it may cause seal failure.

IMPORTANT: Use a tube of soft metal and similar internal diameter to avoid scratching the shaft.

6. Insert the first ball bearing in the backside of the shaft according to the bearing arrangement to be used. Align it with the shaft and press by the inner race preferably with a tube of similar internal diameter until it reaches the shoulder of the shaft. Do not exceed $\frac{3}{4}$ ton of load in the hydraulic press.

IMPORTANT: Use a tube of soft metal and similar internal diameter to avoid scratching the shaft.

CAUTION: Do not damage the exposed thread on the back of the shaft.

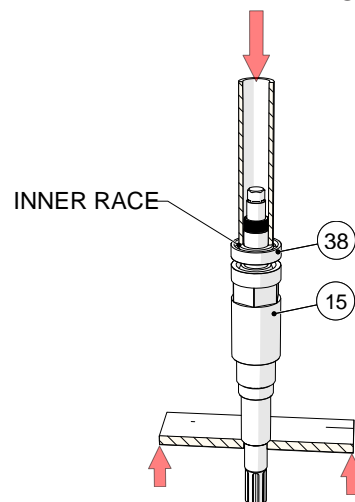

7. According to the bearing arrangement insert the second bearing until it reaches the first bearing. Do not exceed ½ ton of load in the hydraulic press.

IMPORTANT: According to the bearing arrangement type 1, the ball bearing should be pressed by the inner race. According to the bearing arrangement type 2, the ball bearing can be pressed by the inner or outer race.

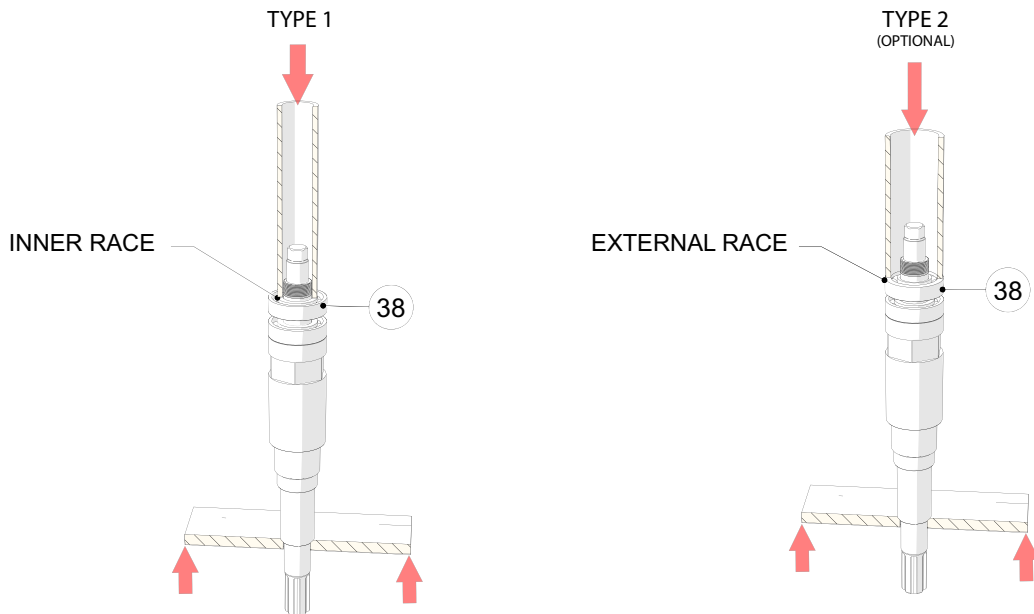

8. Insert the third bearing according to the bearing arrangement and press by the inner race until it reaches the second bearing. Do not exceed ½ ton of load in the hydraulic press.

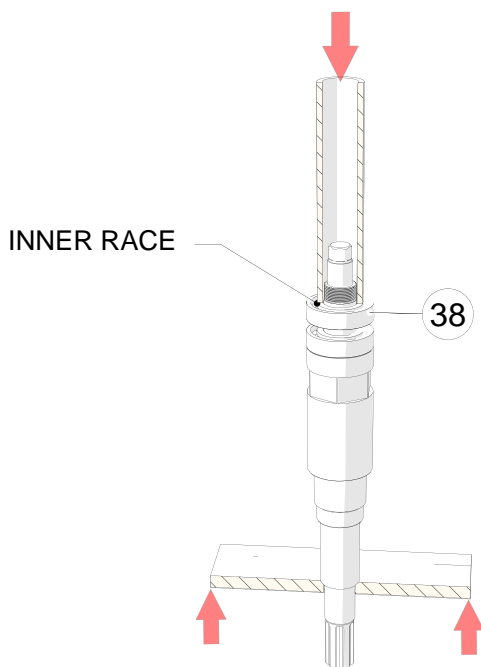

9. On the front side of the shaft, slide in the outer race of the needle bearing (37).

10. Put inside the first groove the remaining retaining ring (36).

11. Repeat these steps in the other shaft.

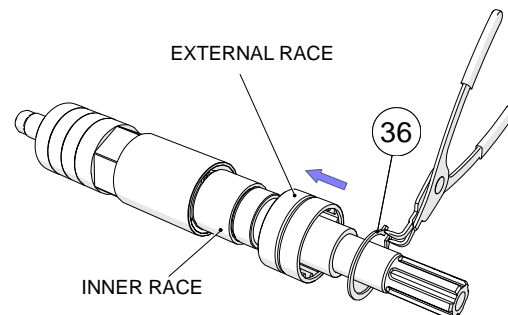

Driven shaft assembly

1. Insert the driven shaft with bearings into the bearing housing **(6)**. The clearance between bearings and it housing is really tight but has no interference.

2. Place the lock washer **(43)** with the inner tab aligned with the shaft keyway.

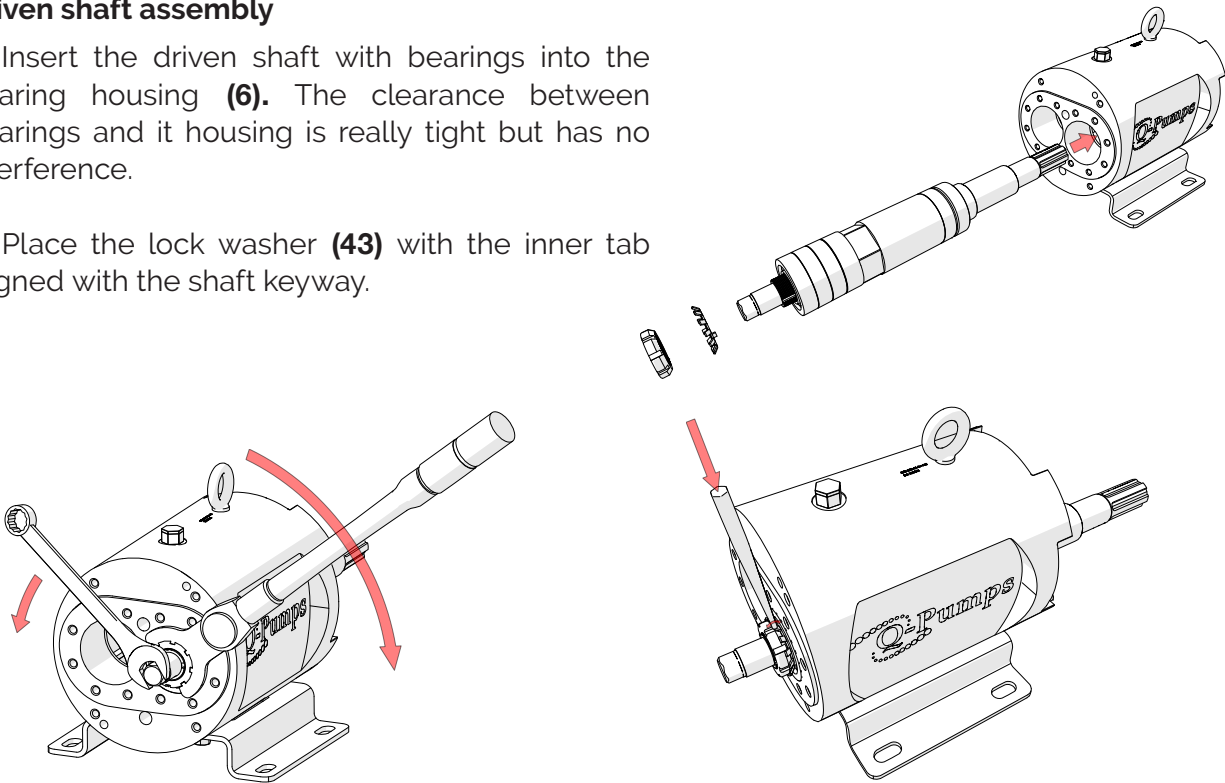

3. Put the bearing lock nut **(44)** and tighten with the QTS special adapter. Use the torque value provided in the torque table **(page 19)**. The torque wrench has to be in line with the adapter.

4. Place the retention flange **(17)** and tighten the screws **(40)**. Use the torque value provided in the torque table. Don't forget the lock washers **(39)**.

5. Insert the driven gear **(42)**. It can go with the tapered rings **(18-19-20)**.

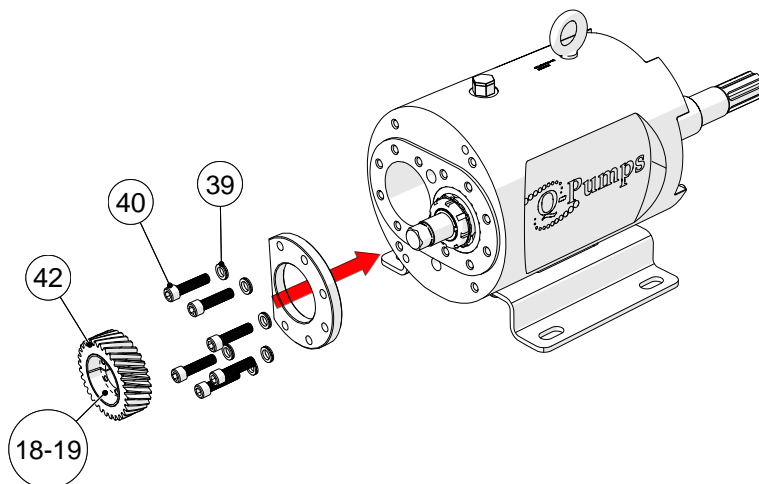

Drive Shaft Assembly

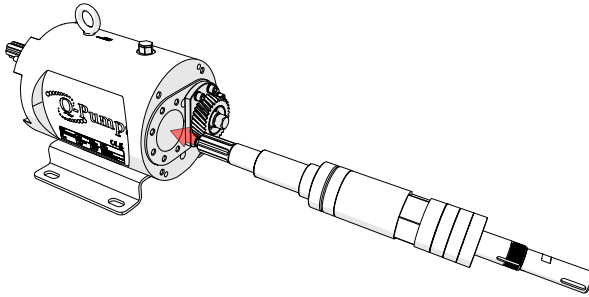

1. Insert the drive shaft with bearings into the bearing housing **(6)**. The clearance between bearings and it housing is really tight but has no interference.

2. Place the retention flange **(17)** and tighten the screws **(40)**. Use the torque value provided in the torque table. Don't forget the lock washers **(39)**.

3. Insert the gear spacer **(16)** until it touches the bearings.

4. Place the gear key **(34)** in the shaft keyway and insert the drive gear **(41)**

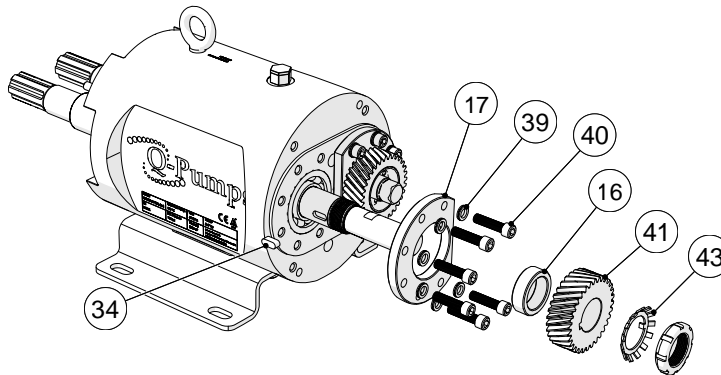

5. Insert the lock washer **(43)** with the inner tab aligned with the shaft keyway.

6. Put the bearing lock nut **(44)** and tighten with the QTS special adapter. Use the torque value provided in the torque table (**page 19**). The torque wrench has to be in line with the adapter.

7. Continue in the rotor synchronization section.

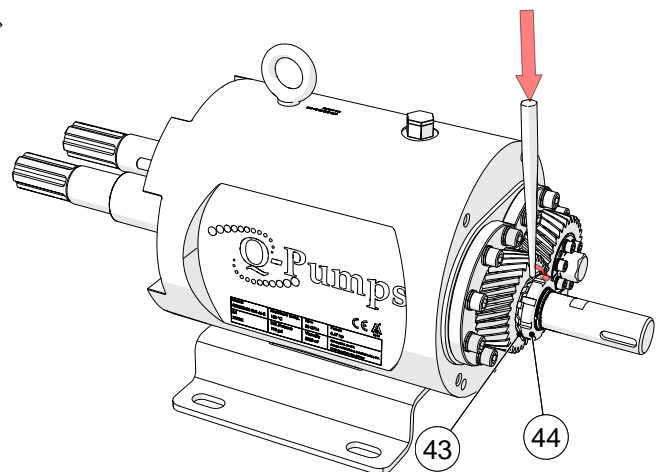
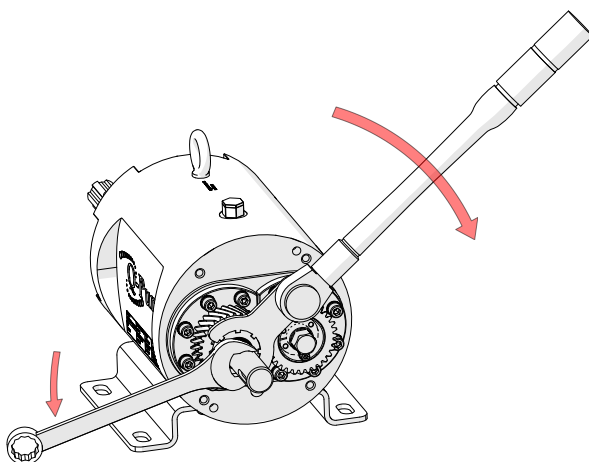









Important Notes

1. Use a six points female socket preferably to loosen and tighten the front cover nuts to prevent marking them.
2. The wet parts comprises the front cover **(1)**, rotor nut **(11)**, rotors **(2,3)**, pump casing **(4)**, mechanical seals **(12)** and the back cover **(5)**. Check that these components are free from damage such as hit marks, abrasion from fluids, or any deformation caused by foreign objects. If considerable damage exists and the pump efficiency is reduced, contact your distributor for spare parts. Be aware that any damage in the casing or rotors can cause pump malfunctioning due to its small clearances.
3. If any of the gaskets or O-rings are damaged (marks, wear or deformation) replace them all together; use a replacement kit for gaskets and O-rings of the same material according to the pump application (either EPDM or Viton).
4. All gasket grooves must remain intact; otherwise the presence of hits or marks may result in leakage.
5. Always use a six points female socket to loosen and tighten the rotor nuts to avoid indentations.
6. The dowel pins surface finish is rectified. If they are damaged, replace them to prevent assembly problems.
7. Synchronization or rotor assembly is incorrect if rubbing marks are shown between the rotors. So if its necessary to replace rotors also it is necessary to repeat the gear synchronization procedure. Please contact Q-Pumps for instructions.
8. You may use water or a FDA food grade silicon base lubricant to lubricate O-rings and gaskets.
9. When an O-ring is damaged, it is highly recommended to replace the entire set of O-rings (including both shafts) at the same time to ensure the service life.
10. The seal faces are very fragile, handle and place them with care to avoid breaking.
11. If any seal face is scratched, hit or damaged, it is highly recommended to replace the entire seal kit to ensure the service life.
12. Ensure that the drag pins match the notches on the seal elements for the right position and assembly.
13. Every double mechanical seals without exception should be properly lubricated. Even the shortest time operating without lubrication may damage the mechanical seals. The flush system must be installed before starting the pump.



14. Cavitation of the pump can cause noise and vibration which can damage the mechanical seals. If cavitation is detected, gather all system information available and verify the application. Remember that your equipment was selected for a particular application and any other use without prior consent may result in damages that can void the pump warranty.
15. When assembling the rotors they should be contact free.
16. Rotors are inside the casing and their front faces must be aligned.
17. Use the torque values (according to the pump model) on the components that are indicated.

RISKS TO CONSIDER

Risk	Description	Considerations
 Crushing, cutting, entanglement	Possible only if guards are not installed, or if pump is running with piping disconnected.	Ensure that guards are installed. Do not open the pump while running or energized.
 High-pressure fluid ejection	Possibility for connection malfunction or hose rupture, depending on installation. Pump casing components designed to hold pressure up to full rated level.	
 Ejection of transmission parts	Imp properly tightened coupling set screws may be ejected, but would be contained by properly installed guard. Seal may shatter and eject pieces in unusual circumstances.	When handling the pump use protective gear.
 Electrical and electrostatic	Incorrect wiring of motor by end user may result in improper grounding or shorts - must refer to supplied motor manual. In some circumstances, fluid running through pump can generate static electricity - use of a grounding strap mitigates this risk.	
 High Temperature	Pump alone will not tend to run at potentially injury-causing temperatures; however, pumping of hot fluids will cause the exterior of the pump and piping to become hot as well. System integrator or plant operator must take responsibility for proper safeguards in such specific applications.	When handling the pump use protective gear.
 Incorrect assembly	Imp proper assembly may lead to part ejection or fluid leak hazards as described above.	Read Manual before giving maintenance to the pump.
 Material	Pumps supplied to food or pharma applications are designed in accordance with 3A, EHEDG, or other applicable industry standards.	Verify material compatibility with the fluid pumped.
 Noise	Pump noise can exceed 80 dB under certain operating conditions. Personnel exposed to elevated noise levels for prolonged periods must use suitable hearing protection.	When handling the pump use protective gear.



TROUBLESHOOTING

Symptom	Cause	Solution
Pump is not running	Drive motor is not running	Check connection or VFD configuration.
	Rotors are in contact	Check synchronization. Resynchronize if necessary.
	Keys are sheared or missing	Inspect and replace if necessary. If keys are sheared, inspect the entire pump for rotor/rotor contact or rotor/body contact.
No flow delivered	Rotors are turning in wrong direction	Check connection or VFD configuration.
	Discharge port is closed or blocked	Open discharge valves
	Inlet port is closed or blocked	Open inlet valves
	Pump speed is too low	Increase pump speed
Inadequate flow	Speed is too low or too high	Check pump curve and adjust speed
	Air leaks in inlet line	Check for bad seals, bad gaskets and piping connections.
	Net inlet pressure is too low	Check pump requirements and change system or pump if necessary.
	Product viscosity is greater than expected	Change system parameters, reduce inlet length and/or increase inlet piping diameter.
	Product viscosity is lower than expected	Increase pump speed
	Rotors worn out due to pumping of abrasive fluids	Increase pump speed Change rotors
Leaks	Mechanical seals broken	Inspect seal faces and replace if necessary.
	Mechanical seals not installed properly	Check mechanical seal assembly.
	Missing o-rings or gaskets	Check mechanical seal and pump body assembly.
Excessive power is required	Viscosity losses higher than expected	Decrease pump speed
		Change system parameters, reduce inlet length and/or increase inlet piping diameter.
	Pressures higher than expected	Reduce pump speed Modify outlet line size
	Viscosity is higher than expected	Heat product or change system parameters
	Mechanical components in contact	Check pump assembly. Verify that all dowel pins are in place.
Noise due to cavitation	Net inlet pressure is lower than required	Check system setup and change speeds and temperature accordingly.
Noise due to mechanical contact	Rotors not synchronized properly	Check synchronization. Resynchronize if necessary.
	Rotors are in contact with body	Check pump assembly. Verify that all dowel pins are in place.
	Pressure is higher than pump rating	Check system and change.
		Reduce pump speed
	Gears are worn	Inspect and replace if necessary.
	Bearings are worn	Inspect and replace if necessary.
	Coupling misalignment	Check coupling alignment
Improper piping support	Support inlet and outlet piping correctly. Don't let the pump carry the load.	
Short pump life	Product is abrasive	If rotors are standard, change to hardened rotors. Change to a larger pump with lower speeds
	Pump speed is higher than application rated	Check system and modify to reduce pump speed.
	System pressure is higher than application rated	Check system and modify to reduce pump speed.
	Improper bearing and gear lubrication	Inspect and replace if necessary. Keep correct oil change intervals.
	Water build up in bearing and gear case	Check that all plugs are in place
	Coupling misalignment	Check coupling alignment

RISKS TO CONSIDER

ANNEX A: CIP cleaning process / sterilization

Cleaning guidelines for CIP (Clean In Place) systems with QTS Series

At the end of each production run, it is important to ensure the maximum recovery of pumped product residues. The QTS design allows 100% draining in vertical as horizontal position.

The QTS pumps have the ability to pump low viscosity fluids at high speed for creating turbulent flow and working as CIP supplier equipment.

Cleaning procedure for QTS pumps

The type of fluid being pumped and its characteristics affect the cleaning strategy, for example cleaning methods suitable for dairy products may not be suitable for juice products, blood or chocolate.

The cycle times, temperatures, cleaning mediums and concentrations of the detergents used will all influence the effectiveness of the cleaning cycle, that's why care must be taken when defining these to ensure that they are suitable for use with the particular product being pumped.

The best way to improve CIP efficiency is to implement structured guidelines and procedures. Cleaning according to schedules and defined guidelines increase the control over cleaning parameters to ensure fluid safety and quality. Be careful to determinate the right guidelines for each type of fluid.

Chemical compatibility between the cleaning detergents and the pump wet elements (construction of SS 316L) should be verified. Ensure for positive displacement pumps the correct temperature clearance rotors are fitted for the CIP cycle.

It is recommended that a differential pressure of 2 to 3 bar is created across the pump to promote efficient cleaning; use valve(s) during the CIP cycle to promote pressure and flow variations that may enhance the cleaning process.

In the case the same pump is used as CIP pump, there must be enough cleaning substance flow. If another CIP pump supply is used, ensure that this pump is flooded in the suction at the rate of their own displacement or in the other hand is pressurized due to the pump itself being as a restriction to the flow.

Internationally accepted protocol for CIP suggest that during all phases of the CIP cycle, a pipeline velocity between 1.5 m/sec and 3.0 m/sec is required. Velocities within this range have proven to provide effective cleaning, although as a general rule the higher the velocity the greater the cleaning effect.

The following table shows the recommended flow in GPM (LPM) for CIP :

Pipe diameter		1.5	2.0	2.5	3.0	4.0	6.0
Speed	1.5 m/s	24 (91)	42 (159)	68 (257)	99 (375)	177 (670)	410 (1552)
	3.0 m/s	48 (121)	84 (318)	136 (295)	198 (749)	354 (1340)	820 (3104)

Here is shown a general but effective cleaning process guideline, a typical cleaning cycle incorporating five stages that are as follows:

1. An initial rinse of clean, cold water.

Rinse with clean water at ambient temperature to remove any remaining residue, 10 to 15 minutes are usually sufficient for this part of the cycle but this will depend on the condition and volume of the residue to be removed.

2. Rinsing with an alkaline detergent.

Rinse with an alkaline detergent, typically a 2.5% solution of Caustic Soda (NaOH) at 70 °C to 95 °C (158 °F to 203 °F) for a period of 10 to 30 minutes could be used. It is also common to add a wetting agent (surfactant) to lower the surface tension of the detergent and hence aid its cleansing ability. This phase of the cleaning cycle should dissolve and remove organic matter such as fats and proteins.

The detergent solution may vary depending on the properties of the fluid being pumped.

3. Intermediate rinse with cold water.

Intermediate rinse with clean water at ambient temperature for a period of 5 to 10 minutes. This phase should remove any residual detergents.

4. Rinsing with an acidic disinfectant.

Rinse with an acidic disinfectant, typically a 2.5% solution of Nitric Acid (HNO₃) at ambient temperature for a period of 10 to 15 minutes would be used. This phase of the cleaning cycle should remove proteins, mineral salts, calcium oxides and other deposits.

5. Final rinse with clean cold water.

Final rinse with clean water at ambient temperature for a period of 10 to 15 minutes or until all traces of the cleaning fluid has been removed.

During the CIP cycles it is important that the required concentration of cleaning detergents is maintained constant. A significant increase in concentration could cause damage to the pumps and other components in the system. A significant decrease in concentration could affect the detergent's cleaning efficiency. A facility for monitoring and adjusting the detergent concentration should be considered.

Consideration should be given to the disposal or recycling of used cleaning liquids and the potential requirement for handling concentrated detergents. Specialists should make the final selection of cleaning detergents/disinfectants.



After CIP cleaning an additional sterilization in place process (SIP) may be required when highly sensitive products are handled, inactivating any micro-organisms which might be still present in the pump. The sterilization can be carried out by means of chemicals, hot water or steam. In the dairy industry the sterilization temperature is approximately 145 °C (293 °F). Contact Q-Pumps in case of temperatures above 100 °C (212 °F).

Because of QTS pumps are capable of supplying the CIP fluid running at high speed please provide system information for selecting the right values of rpm for CIP supply.

Normally when ordered, the QTS Pumps are selected for both, the application and for the CIP supply.

ANNEX B

Nut-and-Locknut Technique

The nut-and-locknut technique serves to prevent a nut from loosening by superimposing another nut.

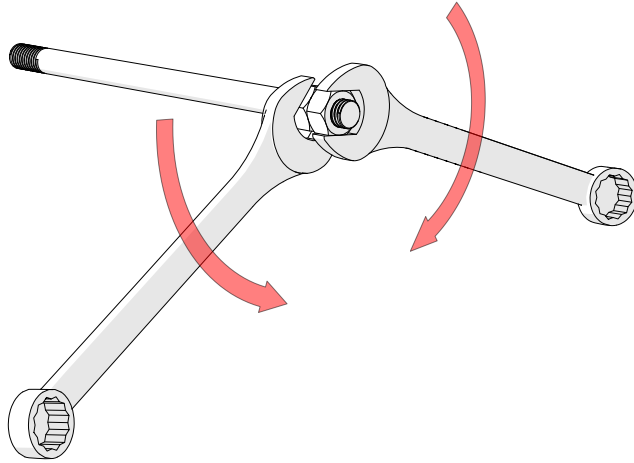

Thus it is possible to use as a fastening device. This technique is useful to remove and tighten the studs from the gearbox.

Two keys are used to tighten a nut against each other, making both nuts fix so they can't loosen.

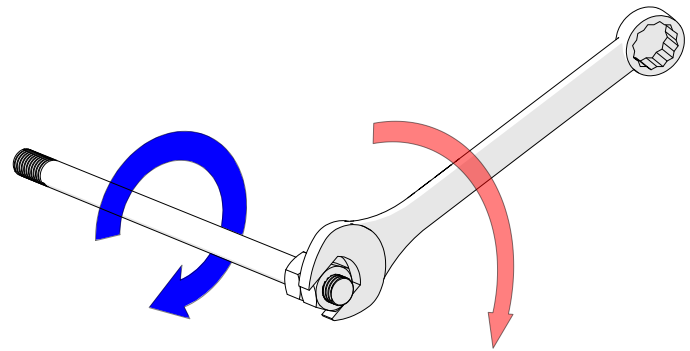

To loosen both nuts two keys are used likewise, now in the opposite direction.

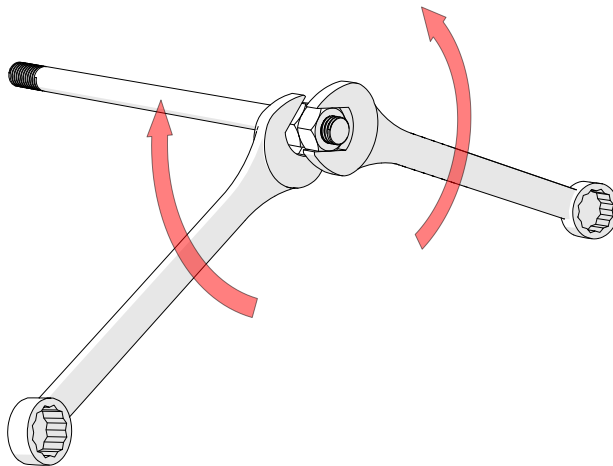



Operation and Maintenance Manual
Positive Displacement Pump
QTS Series Twin Screw Pump

Acceso "A" #103, Fraccionamiento Industrial
Jurica, Querétaro, Qro., México. C.P. 76130
Call: +52 (442) 218 4570 / 218 7400
Fax: +52 (442) 218 4577

support@qpumps.com

www.qpumps.com